

DAELIM

OWNER'S MANUAL

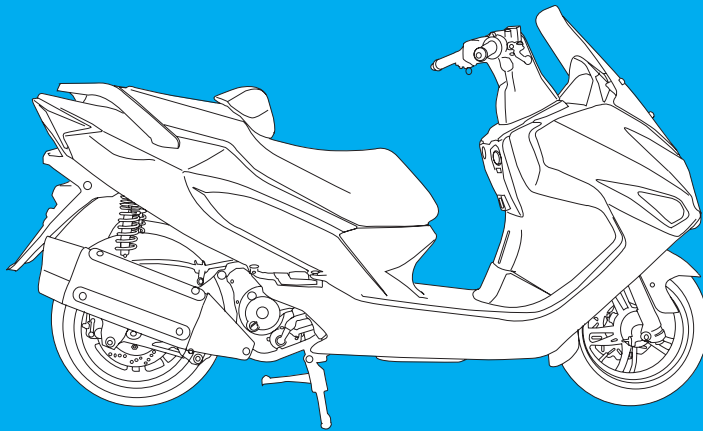

IMPORTANT NOTICE

- WELCOME

Thank you for purchasing an Daelim vehicle. We hope you enjoy safe riding.

- OPERATOR AND PASSENGER

This motorcycle is designed to carry the operator and one passenger.

⚠ WARNING

Attempting to change the pre-set maximum speed may cause danger and will void the Daelim warranty.

- ON-ROAD USE

This motorcycle is designed to be used only on the road.

- READ THIS OWNER'S MANUAL CAREFULLY

Pay special attention to statements preceded by the following words:

⚠ WARNING

Indicates a strong possibility of severe personal injury or death if instructions are not followed.

⚠ CAUTION

Indicates a possibility of personal injury or equipment damage if instructions are not followed.

⚠ NOTE

Gives helpful information.

This manual is an important and integral part of your vehicle. keep it with your vehicle at all times, even though your vehicle is resold.

CONTENTS

SPECIFICATION	3	PROPER DRIVING METHODS	21
OPERATION INSTRUCTION(SAFETY PRECAUTIONS) ..	4	DRIVING IN A SLOPING ROAD	24
PRIOR TO STARTING VEHICLE / OPERATION	5	SELF INSPECTIONS BEFORE OPERATION	25
CORRECT ATTIRE	6	INSPECTION OF SUSPICIOUS AREA OF THE VEHICLE WHEN DRIVIN	
CARGO/MODIFICATION/ATTACHMENT/MUFFLER	7	IN THE PREVIOUS DAY	25
PARTS LOCATION	8	BRAKE INSPECTION	25
METER READING AND USAGE	10	TIRE INSPECTION	26
METER	10	FUEL CHECK	27
INDICATING LAMPS/MAIN SWITCH	11	ENGINE OIL LEVEL CHECK	28
SWITCH OPERATION	12	LIGHT / WINKER INSPECTION	29
START BUTTON / ENGINE STOP SWITCH	12	INSPECTION OF STOP LAMP	29
UP-DONW ADJUSTING SWITCH OF HEADLIGHT	12	BULB REPLACEMENT METHOD	29
PASSING SWITCH / HORN BUTTON	13	MAINTENANCE SCHEDULE	32
WINKER SWITCH/ EMERGENCY SWITCH	13	SIMPLE MAINTENANCE / REPLENISHING FRONT, REAR BRAKE FLUID ..	34
SEAT BUTTON	13	BRAKE HOSE, PIPE LEAKAGE,DAMAGE,ASSEMBLY STATE	34
EQUIPMENT USAGE	14	FRONT, REAR BRAKE PAD	35
AT STARTING	14	CHANGING ENGINE OIL	36
REPLACEMENT OF THE SMART KEY'S BATTERY	15	FRONT, REAR BRAKE PAD	37
STEERING STEM LOCK / ADJUSTING REAR CUSHION	15	COOLING WATER REPLACEMENT	38
OPERATION	16	CLEANING OF TERMINALS OF BATTERY	39
SEAT LOCK / TRUNK	16	FUSE REPLACEMENT	40
SEAT BACK REST / INNER BOX LID / CHARGE SOCKET	17	AIR CLEANER ELEMENT INSPECTION	41
CORRECT DRIVING OPERATION/ ENGINE STARTING	18	CVT DUST COVER ELEMENT INSPECTION, CLEANING	42
AT STARTING	19		

CABLE RUBBER PART	42
SIDE STAND INSPECTION	43
CLEANING	43
INSPECTION SHEET	44
DAILY INSPECTION(BEFORE DRIVING)	45
REGULAR INSPECTION	45
ABOUT REGULAR INSPECTION	46
DAILY INSPECTION, REGULAR INSPECTION	47
RECOMMENDED REPLACEMENT PARTS	49
STEERING STEM LOCK	50
OIL REPLACEMENT AT REGULAR SCHEDULE	50
INSPECTION AND MAINTENANCE	51
DAILY INSPECTION CHECK LIST	52
DAILY INSPECTION METHOD	53
INSPECTION METHOD, TIPS	55
CHECKING POINTS	56
INSPECTION RECORDS	68
SAFE DRIVING(PREPARATION BEFORE DRIVING)	72
DRIVING POSITION	73
TAKING POSE OF FELLOW PASSENGER	74
PRECAUTION WHEN DRIVING	75
STARTING	76

TURNING METHOD	77
PRINCIPLE OF TURN	77
EFFECT OF SPEED	77
3 POSITIONS OF TURNING	78
TURNING METHOD	79
BRAKING METHOD	80
BASIC PRINCIPLE OF BRAKE(FRICTION FORCE)	81
RESTRAINT OF BRAKING EFFECT (INERTIA)	81
BRAKING METHOD	81
COMPARISON OF BRAKING DISTANCE	82
IMPACT WHEN COLLISION	82
WIRING DIAGRAM	84

SPECIFICATION

ITEM		DATA (13 inch)	DATA (14 inch)	ITEM	DATA (13 inch)	DATA (14 inch)	
LENGTH×WIDTH×HEIGHT(mm)		2,110×750×1,200 (1,310 Large W/Screen)	2,140×750×1,215	IGNITION SYSTEM	TRANSISTOR		
WHEEL BASE(mm)		1,500		BATTERY CAPACITY	12V 10AH (MF TYPE)		
GROUND CLEARANCE(mm)		136	143	FUEL CAPACITY (L)	12.7 (1.9)		
SEAT HEIGHT(mm)		745	762	USAGE FUEL	GASOLINE		
DRY WEIGHT(kgf)		159		TIRE SIZE	FR.	120/70 - 13	120/70 - 14
PASSENGER		2			RR.	140/60 - 13	140/60 - 13
ENGINE TYPE		WATER COOLING 4 STROKE 4 VALVE		SUSPENSION	FR.	TELESCOPIC	
					RR.	UNIT SWING	
PISTON DISPLACEMENT(cc)		124		BRAKE	FR.	HYDRAULIC DISK	
BORE AND STROKE(mm)		56.5 × 49.5			RR.	HYDRAULIC DISK	
STARTING SYSTEM		STARTING MOTOR		SPARK PLUG	CR8EH - 9		
TRANSMISSION TYPE		CVT		FUSE (A)	15 / 30		
ENGINE OIL (L)	TOTAL	1.3		COOLING WATER (L)	1.5		
	REPLACEMENT	1.1					

OPERATION INSTRUCTION

This manual describes matters pertaining to correct operation, safe operation and simple maintenance of the vehicle you purchased.

To ensure more comfortable and safer operation, make sure to read this manual carefully prior to operation.

- The photographs and drawings shown in this manual may differ from those of actual vehicles due to changes in vehicle specifications and modifications made.
- This vehicle is designed for 2 riders including the operator.

⚠ CAUTION

- Do not use polluted gasoline.

Using polluted gasoline will cause rust inside the fuel tank, and will close the supply of fuel to the carburetor, leading to an improper engine starting or may cause serious damage to an engine.

- Do not use polluted or low-grade oil.

Always use genuine oil to protect and extend vehicle performance and its life span.

- If any failure occurs due to the use of polluted gasoline or oil, such failure will be excluded from being eligible for repairs under the warranty.

SAFETY PRECAUTIONS

- Careful driving and the wearing of proper attire and safety equipment are the most important factors in the safe operation of the scooter. Please obey traffic regulations and do not be hurried and careless.
- Many new vehicle owners operate their newly purchased vehicles with great care and attention to safety factors. However, after becoming accustomed to the operations are often discarded, which can lead to accidents. Please don't let this happen to you and always approach the operation of your vehicle with the safety considerations needed. When operating the vehicle, always keep in mind and obey the notes of precaution printed on the "Safety Precaution Label" attached to the vehicle.

- Be sure to wear helmet at all time.
- Be sure to put on gloves at all time.
- Observe the speed regulations.
- Beware of muffler after driving as it is still hot to be burnt. Especially never children touch on it.
- For safety, do not change, alteration or modification the vehicle.
- Regularly conduct specified maintenance inspections.
<Maintenance Inspection Points>
Brakes, Tires, Oil, Lights, Horn, Instruments

PRIOR TO STARTING VEHICLE

- Read user's manual carefully.
- Conduct maintenance checks prior to operation.
- Always maintain vehicle in clean status and carry out specified maintenance checks.
- Make sure to stop engine and stay away from fire when fueling.
- Exhaust gas contains harmful substance such as carbon monoxide. Start engine in well-ventilated places.

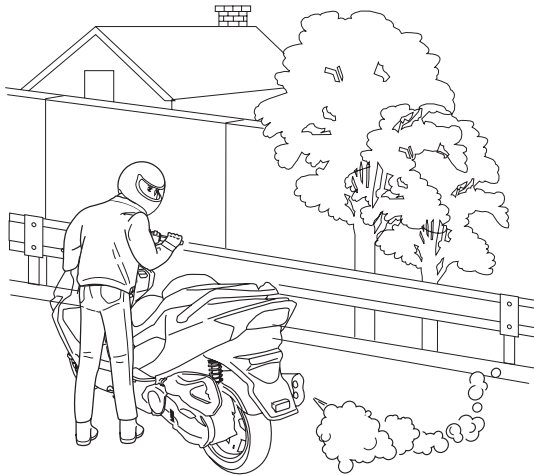

OPERATION

- Operators should naturally fix bodies to keep smooth driving.
- Please check whether or not you are unnaturally strained and strung up.
- Driving pose has a great influence on safe operation. Please always maintain the center of your body in the middle of seat. Especially do not sit at the rear seat because it may lessen the weight of front wheel and cause trembling steering wheel.
- A passenger should hold on to the vehicle or the operator with both hands and keep both feet on the pillion step bar.
- When wanting to turn, slightly lean to body toward the direction of the turn. It is unsafe if the body is not moved in union with the vehicle.
- Curvy roads and poor, unpaved roads constantly change in surface quality. Driving on these roads can be unsafe if certain safety precautions are not followed.
- In order to safely drive through these driving conditions, anticipate coming road conditions, slow down to at least half the normal speed, and relax your shoulders and wrists while securely holding the handles.

CORRECT ATTIRE

- Always make sure to wear helmet for safety. Wear gloves and safety goggles.
- Do not wear uniforms which might hinder operation. It is dangerous if the uniform is caught by brake lever or by the rotating part of drive chain.
- Many automobile/motorcycle accidents happen because the automobile driver does not “see” the motorcyclist. Make yourself conspicuous to help avoid the accident that wasn’t your fault :
 - Wear bright or reflective clothing.
 - Don’t ride in another motorist’s “blind spot”.

WARNING

- Be sure you and your passenger always wear a helmet, eye protection and other protective apparel when you ride.
- Not wearing a helmet increases the chance of serious injury or death in a crash.

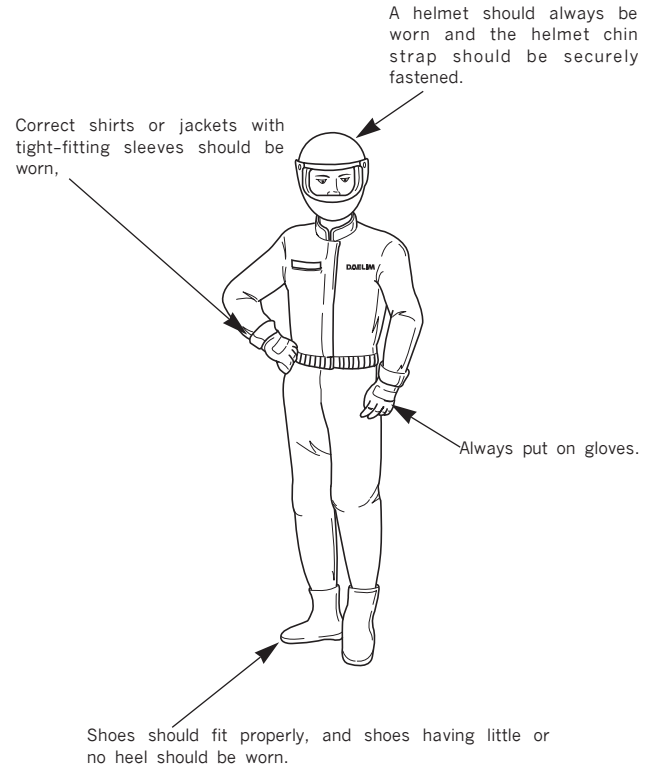

CARGO

- When carrying cargo, you must keep in mind that operating the motorcycle, especially when turning, will be different.
- Make sure not to overload the motorcycle with goods as this can make the motorcycle unstable during operation.

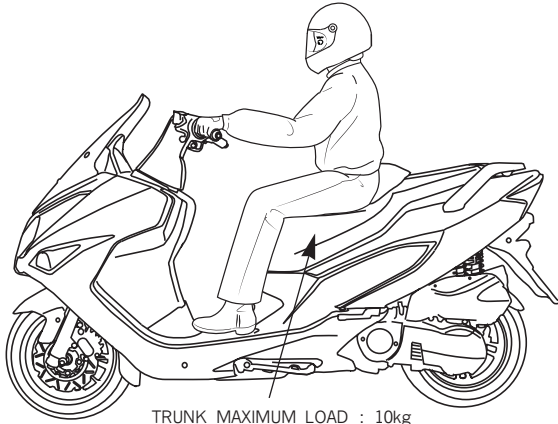

TRUNK MAXIMUM LOAD : 10kg

CAUTION

- Only load cargo in or on designated areas as placing or fastening cargo to other areas can cause damage to the vehicle.
- Do not place articles between the frame body cover and engine as this can burn the goods.

MODIFICATION

- Modification of vehicle structure or function deteriorates manipulatability or causes exhaust noise to become louder shortening the vehicle life. These modifications are not only prohibited by law but also are the acts harmful to other people. Modifications are not covered by warranty.

ATTACHMENT

- Except designated attachment by DAELIM MOTOR CO., LTD., don't attach any extra lighting device, because it may cause an early discharging of battery.

MUFFLER

- Pay particular attention to fellow passenger so that he/she can prevent getting burnt by the hot muffler during travel.

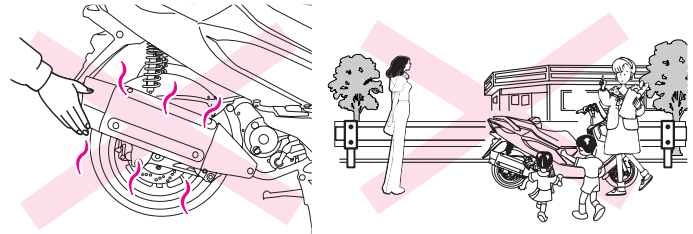

PARTS LOCATION

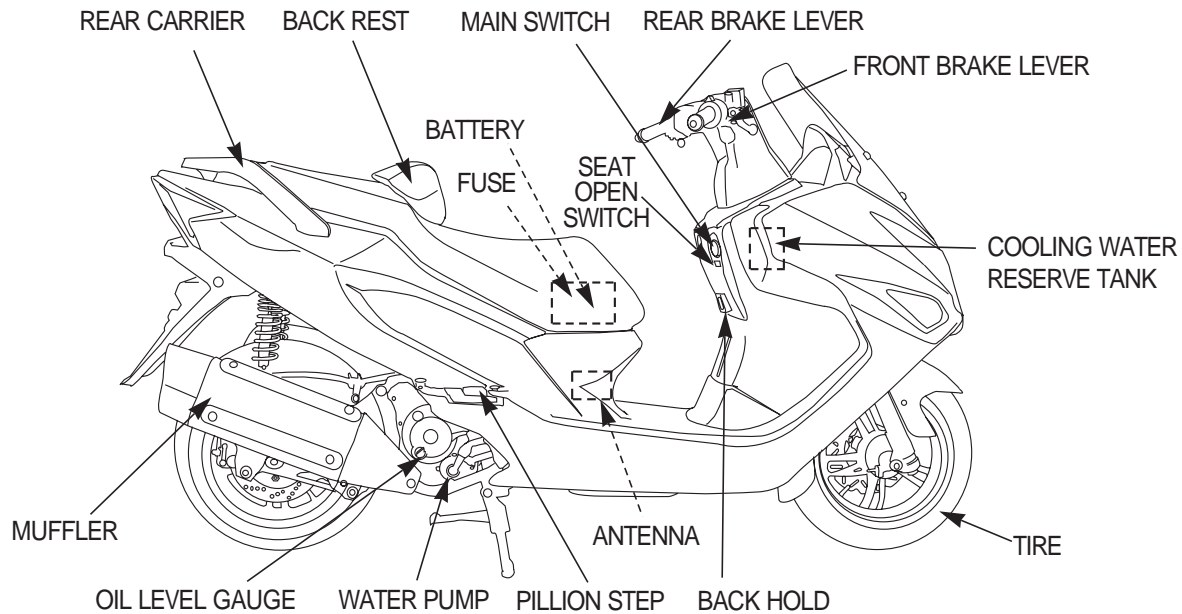

PARTS LOCATION

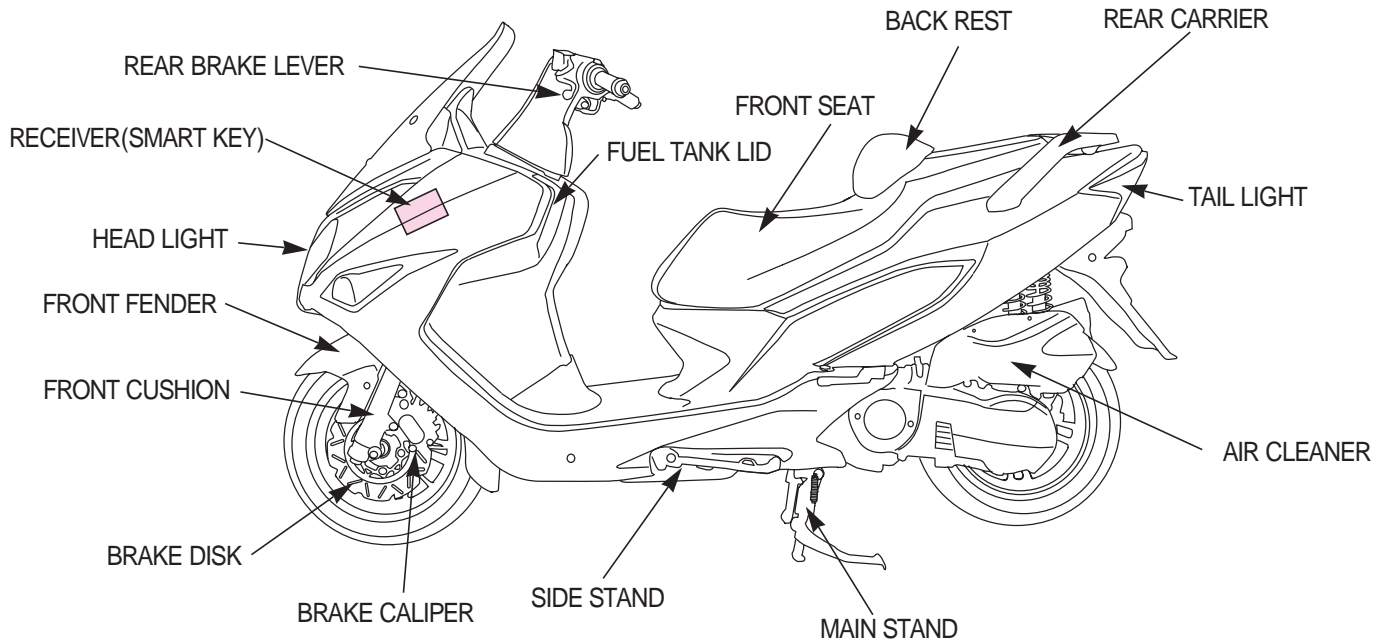

METER READING AND USAGE

METER

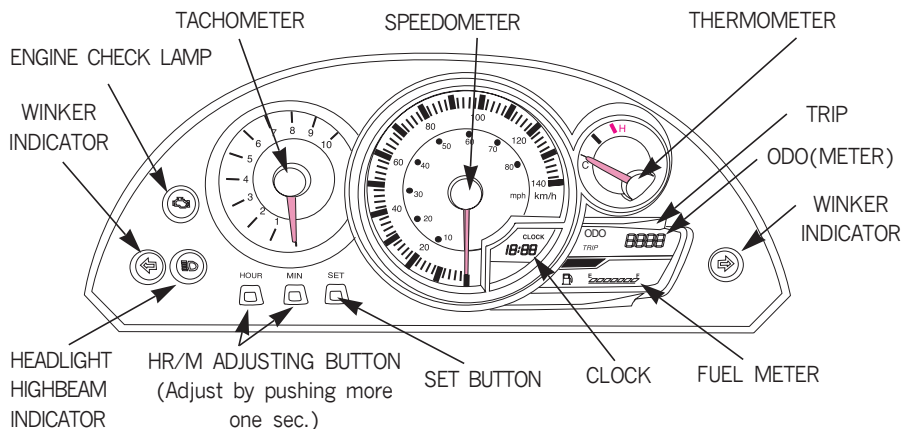

<SPEEDOMETER>

Indicates driving speed. Maintains legal speed limit to ensure safe operation.

<ODO : Odometer>

Indicates total distance in kilometers travelled by the vehicle.

<TRIP : Trip>

Before starting, push the 'SET BUTTON' and select 'TRIP'. If pushing more 2(two) seconds, it indicates '0'. Next, the distance by pushing again till '0' will be indicated on 'TRIP'

<CLOCK (to fit the correct time)>

If you push HOUR/MIN button for more 1 second, HOUR/MIN lamps. Then, adjust hour and minutes by that button.

<RPM(Tachometer)>

It indicates engine RPM per one minute(x 1,000 rpm).

NOTE

- During riding, please drive the scooter in order that the RPM of engine shall NOT be positioned in the dangerous area(red area) of tachometer.

<Thermometer>

It indicates the temperature of cooling water. If the gauge of thermometer indicates below the middle, it means 'Normal limit'.

FUEL METER

<Fuel meter>

The fuel meter indicates the gasoline level inside the fuel tank. Gasoline should be put in the fuel tank as soon as possible if the needle is resting in the red area.

Fuel tank capacity	Reserve fuel capacity
11.5 L	1.9 L

WARNING

- If driving continuously within the area 'I' of fuel meter, the fuel can be consumed totally. Because of total fuel consumption, it results in the vehicle stop and it may occurs the collision from the behind vehicle to happen serious damage or even death.

METER READING AND USAGE

INDICATING LAMPS

<Winker indicators / Emergency lamp>

The lever of main switch shall be, lift up the emergency lamp switch, the emergency lamp lights.

<Engine Check lamp(indicates repair and maintenance)>

If there is something wrong in sensor relating with engine controlling system to control the regular operation of engine or emission gas control system, this Engine check lamp lights. During riding, if it lights, visit the designated service shop to request the repair as soon as possible.

⚠ CAUTION



- If you keep riding the scooter even at the engine check lamp lighting, it may occur damage to the emission control system to effect driving performance and fuel consumption. Also, you may get restriction relating with emission gas regulations then take precautions about it.
- When the engine check lamp lights, it may occur damage to the catalyst system then causing getting the engine power lower. So, please request the designated repair shop to repair as soon as possible.

SWITCH OPERATING

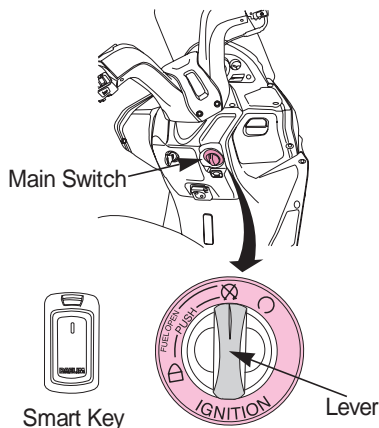
MAIN SWITCH



Pushing the lever

- If push the lever, search the Smart Key and be completed the certification of the vehicle, then at the time when blue lamp lights, the tuning from  (OFF) to  (ON) can be done. (within 5(five) seconds).
 (ON)
- This indicates the engine is able to be operated. At the time that blue lamp lights, the rotating can be done(the voltage will be supplied at electrical diagram)

 (OFF)

- The position of Engine stop.

 (STEERING LOCK)

- Push the lever, turn to the left, the steering will be locked(In order to release steering lock, push the lever and if the certification of Smart key is OK, the lever can be rotated.)

(FUEL CAP OPEN)

- The cover of fuel cap opens.
- Push the lever then certificate Smart key, tum the lever to the left, the cover of fuel cap will open.

⚠ CAUTION

- Only when the Smart key positions with vehicle antenna within 1(one) meter, the main switch system can be operated.
- If leaving after parking the vehicle, be sure to rotate the lever position to OFF or LOCK. (At the status of lever ON, starting is available regardless of smart key.)
- In this vehicle, by using the Smart key, only pushing the starter button can the vehicle to be started. At being operated, the headlight always lights. If you intentionally remove always turn on lamp diagram, at night, during night riding, you may not able to see the front side then it occurs collision and other accidents.

SWITCH OPERATION

START BUTTON

Be the main switch lever \odot (ON), grip the brake and push the starter button, the engine operates(the green lamp lights).

⚠ CAUTION

- If you do not grip the front or rear brake lever, the engine can not operate.
- At starting, do not pull the throttle grip by gripping the brake lever. If so, the vehicle performance can be lower because of the earlier heating of transmission, and if you release the brake, the vehicle can suddenly start to occur the accident

ENGINE STOP SWITCH

START BUTTON

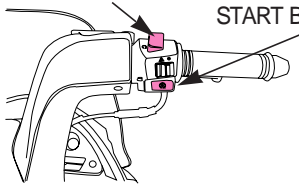

ENGINE STOP SWITCH

Engine stop switch is the equipment to stop the engine.

⚠ WARNING

- Do not use the engine stop switch except the emergency or stop.
- During riding, if operate the engine stop switch to \otimes (OFF), the engine can be stopped then it occurs collision, turning over, etc that can happen serious damage or death.

UP-DOWN ADJUSTING SWITCH OF HEADLIGHT

<Lighting method of headlight>

If the vehicle starts, the headlight turns on. In order to prevent the unnecessary discharge of battery, this vehicle adopts the automatic lighting system of headlight at the same time of vehicle operation.

⚠ NOTE

- The ' Always Turn On ' system of headlight gets the rider to be able to drive safely by the scooter visibility on the road then the vehicle's position to be acknowledged easily. Also, especially at the time sunset or bad weather conditions, it gives good effect. (However, the headlight shall be downward for the purpose that riding vehicle from the opposite way can not be interrupted.

⚠ CAUTION

- The usage of upward light shall be only used on condition that it does not interrupt the former positioned vehicle's driving.



<Adjusting switch to up-down of headlight>

- ≡D (upward)...Use only at the time of lighting the headlight far away.
- ≡D (downward)...At riding, this is the main lighting mode when lights nearby.

Up - down switch of headlight

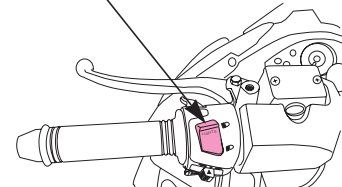

PASSING SWITCH

If the main switch lever is \odot (ON), push it 2 or 3 times. This switch is used when passing the other vehicle.

Passing Switch

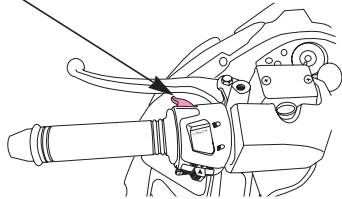

HORN BUTTON

Horn Button

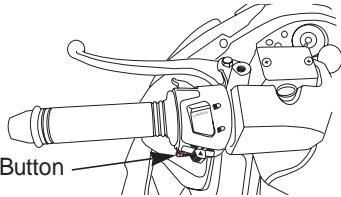

If the main switch lever is \odot (ON), push the horn button make horn sound.

WINKER SWITCH

Winker Switch

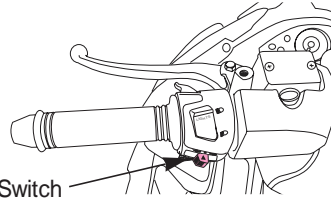

If the main switch lever is \odot (ON) and put into the winker switch, the winker (winker indicator) operates.

(R).....to the right.

(L).....to the left.

⚠ CAUTION

- The winker switch does not return automatically. If finishing to use it, surely return the winker switch to the original position.
- If you forget returning, this may occur to interrupt the other vehicle's riding.

EMERGENCY SWITCH

Emergency Switch

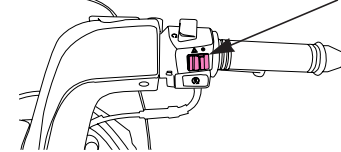

Regardless of main lever switch position, the emergency switch can be operated. (If the emergency switch operates for a long time, this may cause battery discharge.)

SEAT BUTTON

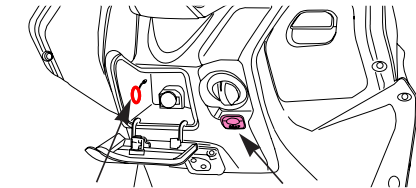

Seat Wire Loop

Seat Button

If the Smart key is within 1 meter, push the seat button then the seat opens. But, at the time that the battery of the vehicle or the Smart key's battery are discharged or the seat does not open at the area of strong electricity, by using the key to open the inner box lead and pull the seat wire loop, the seat can be opened.

EQUIPMENT USAGE

AT STARTING

The rider gets the Smart key and gets on the vehicle (within 1 meter), turn the main switch lever to the position  (ON), push the button then the vehicle starts.

AT TURNING OFF THE VEHICLE

If the turn the engine stop switch or main switch lever to the  (OFF), the vehicle stops.

NOTE

- After the vehicle being stopped by the engine stop switch, turn the main switch lever to the  (OFF). Otherwise, battery can be discharged early or other person can start the vehicle.

CAUTION

- When the battery is not installed or completely discharged, the vehicle does not start and this occurs the Smart key have something wrong.
- If starting the vehicle by Smart key, surely stand up the main stand and grip the brake, push the 'starter switch' and start.
- The Smart key shall be brought by the rider, if the rider does not have it, the vehicle can not be started.
- If the rider leaves from the vehicle at the vehicle operated, the rider shall stop and do not keep the Smart key at the vehicle. This may occur the vehicle theft.

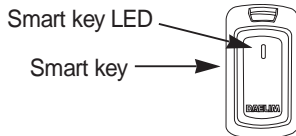

REPLACEMENT OF THE SMART KEY'S BATTERY

If the battery of Smart key being discharged, it may not operates normally. Then, replace its battery promptly. Do not disassemble the 'home' part located at the lower side of Smart key loop. At this moment, do not disassemble surely the part of diagram. Smoothly broaden the fixed loop and remove the used battery, next replace with the new one.

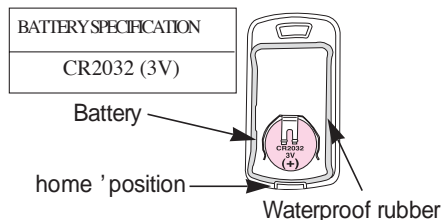

At re-assembly of Smart key, assemble correctly not in order to damage the waterproof rubber.

CAUTION

- Surely check whether the engine stop switch is ON before starting or it has out of order. If the engine stop switch is OFF, starting the vehicle is impossible.
- If you temporarily disassemble or assemble or modify the Smart key temporarily, it may occurs the Smart key to be out of order. If so, the warranty can not be applied.
- When, having the Smart key, posed at the near of the vehicle, be careful so that child or other does not push the engine start switch. If unwanted starting, it may occurs the accident.
- If the battery of Smart key is discharged, the Smarty key does not operate. Then, at operating smart key, if its LED does not light, replace with the new battery of smart key.
- If the vehicle starts, the blue lamp of the main switch lights 10 times rapidly.
- At keeping the Smart key, if you keep it near the electric devices like television, electric oven, computer, note-book, monitor, etc, the battery of Smart key may be worn rapidly. Be careful keeping it at the proper location.
- If you keep the Smart key to the washing machine that complete waterproof is needed for, this may occur the Smart key be out of order.
- In order to prevent the damage of the Smart key, do not fall down or not get wet or not being exposed to the heat, the direct sun light.
- At replacing battery, take precaution about its polarity. This may cause something wrong of smart key.

STEERING STEM LOCK

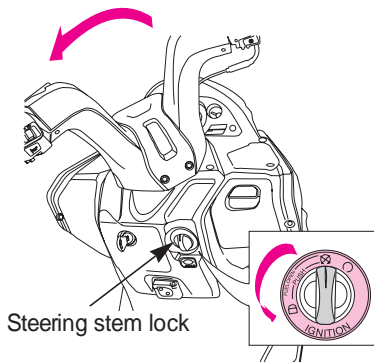

To be theft, surely lock the steering stem lock at parking.

<LOCK>

To lock the steering, turn the handlebar to the left, turn the key to  (LOCK) which pushing in.

<UNLOCK>

By pushing the main switch lever, certificate the Smart key, then if turn to the  (OFF) by smoothly pushing main switch lever, unlock the vehicle.

⚠ CAUTION

- Move lightly the steering stem to the left and the right to check whether it is locked completely to the “ LOCK “ position.
- Park the vehicle at the safe place not to interrupt the traffic.
- If the vehicle is located at sliding place or unstable road , it may be turned over or slipped. At parking or stopping, check completely the safety.

ADJUSTING REAR CUSHION

The strength of rear cushion is adjusted at 5 steps.

The basic step is 2nd.

Depending upon the weight of rider or the road condition, adjust the rear cushion. To adjust, do by turning the adjuster.

⚠ CAUTION

- The adjuster marks of the left and the right shall be the same.

REAR CUSHION

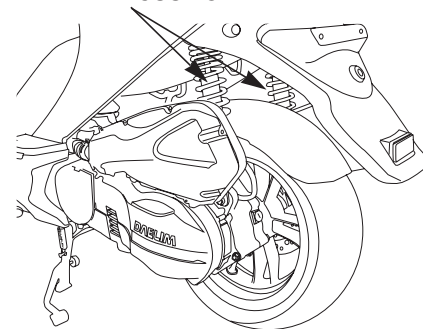

SPRING ADJUSTER

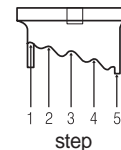

PIN SPANNER

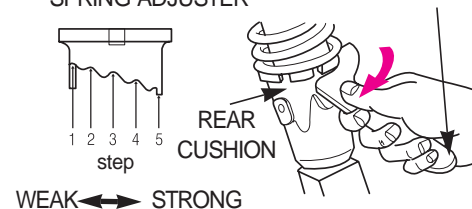

OPERATION

SEAT LOCK

<LOCK>

Push and close the seat, it automatically locked.

Check the seat locked by lifting it slightly.

<OPEN>

When the Smart key is within 1 meter from the vehicle, push the seat button and the seat automatically opens. (But, at this time, the battery voltage shall be in normal limit).

Manual Open.

- Open the inner box lid by the general key, pull the seat wire loop and the seat opens.

⚠ CAUTION

- Be careful about that if closing the seat at the key being in trunk, it automatically closes.
- When the seat lock is out of order, do not use it by force. Visit the designated service shop and request the mechanic to check and repair.

TRUNK

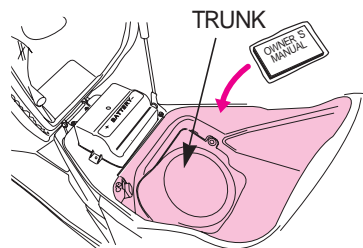

TRUNK MAXIMUM LOAD	10kg
---------------------------	-------------

There is a trunk under the seat.

At opening the seat, the lamp inside it lights

There is a document or helmet storage area inside the trunk.

Store the owner's manual packed in vinyl cover inside the trunk as always.

⚠ CAUTION

- Do not load the excessive cargo in the trunk. If the seat being locked by force, the trunk lamp can not be OFF then the battery will be discharged early (In this case, the rider shall open the seat by hand)
- After closing the seat, check whether the seat completely locked or not. If the vehicle not being locked and you drive it, you may be damaged by the seat opening at sudden stop.
- The temperature inside the trunk rises due to heat from the engine. Do not place foodstuffs and other articles that can be damaged easily by heat. Also do not place flammable materials in the trunk.
- At washing the vehicle, water inflows to the trunk can be done. If you put the important thing into the trunk, be careful to keep it.

SEAT BACK REST

Depending upon the rider's convenience, you can adjust the position of SEAT BACK REST.

Open the seat and untie the screw lever in back side of seat, adjust the position of back rest and lock the screw lever.

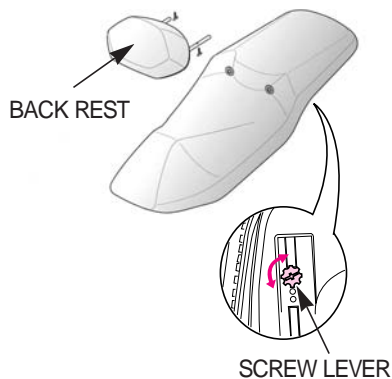

INNER BOX LID

When open or close the inner box lid, use the normal key.

<How to lock>

Turn the normal key to the right and close the cover, next turn it to the left and pull it out.

<How to open>

By turning the normal key to the left, open it.

⚠ CAUTION

- Do not place valuable or fragile thing(s).
- At washing the vehicle, the water may inflows. So, if you place the important thing,

CHARGE SOCKET

At starting the engine, open the inner box lid and put the proper charge socket below 12V, 1A in and use.

⚠ CAUTION

- Use at engine starting.
- When not using, close the inner box lid cover.

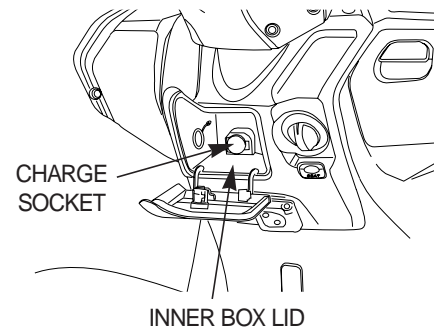

CORRECT DRIVING OPERATION

Make sure to check the oil, gasoline, etc., before starting the engine.

Please ensure that the main stand and side stand are lift up at starting the engine.

At starting the engine, grip the brake as always.

Drive with care for both safety reasons and longer vehicle life.

For 1 month (or 500 km) after purchasing the vehicle, drive moderately avoiding fast starts and fast acceleration.

⚠ WARNING

- Make sure that the rear wheel is locked when starting the engine to prevent an unexpected sudden start of the vehicle.
- At standing the main stand, if accelerating by operating the throttle, the rear wheel may touch the body, then it occurs a serious damage.

ENGINE STARTING

Lock the rear wheel

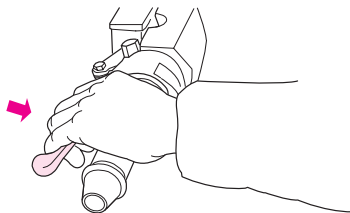

After certifying the Smart key, turn the main switch to the  (ON) position. (Blue lamp lights)
The start is possible when the Smart key is in 1 meter from the vehicle.



Smart key

Press the start button. At operating start, the green lamp of the main switch lever lights.

<USING THE ELECTRIC START(CELL)>

Press the start button without rotating the throttle grip.

At searching the Smart key, the time of certification make take long, keep pressing the start button by the time when the vehicle starts by motor rotating.

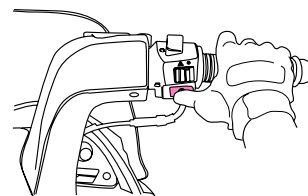

⚠ CAUTION

- Immediately release the starter button as soon as the vehicle has been started.
- Do not push the starter button when the engine is running. This can damage the starting motor.
- If you take the Smart key together cell phone, navigation, note-book computer, metallic material, the communication error between the Smart key and the vehicle may occur then the vehicle may not start.

On condition that the engine is heated, only pressing the starter button gets the vehicle started.

To prevent the battery discharge, do not rotate over 5 seconds the starter motor continuously. If the engine does not start even rotating over 5 seconds, wait over 10 seconds and next press the starter button.

⚠ CAUTION

- When the vehicle overturns, do not operate the starter button right away. If the short circuit may happened due to the damage of starter motor cable surface at the coming out of gasoline, it may occur burn.
- If the short circuit may occur because of the aging of wire protective tube or electric wire tube and there is a flammable thing, it may happen fire accident. Then, please check the regularly checking of the vehicle.

When the engine gets cold, please maintain the vehicle for a moment at the engine started, and get the engine warm.

⚠ WARNING

- When getting on and starting the vehicle, grip the brake lever and maintain braking. If, on conditioned not gripping the brake lever, unintentionally grip the throttle or the cable is not being returned because of freezing or corrosion of the cable, the vehicle may suddenly start that results in the rider's damage by the collision.
- At the vehicle being cold, the emission gas may include harmful component like CO, etc. Because of this, the engine operation in a place being sealed may lose him/her consciousness.

<Tips at starting the vehicle at seriously cold season>

Stand the vehicle up surely by the main stand.

The main switch lever shall be  (ON).

Press the starter button for 5~10 seconds(At this moment, do not rotate the throttle grip).

Start the engine. If it does not start, repeat 2~3 times above 3).

If the vehicle does not start even by repeating 3),4), try 6) to start the vehicle.

Rotating completely(100%) the throttle grip, press the cell starter button about 5 seconds(repeat 2~3 times).

If start, snap smoothly.

⚠ CAUTION

- At seriously cold season, the battery performance usually gets weak and the rotating load of the engine becomes large. Because of them, there may happen bad starting.
- At seriously cold season, putting a cover over the vehicle or placing it indoor are better for starting.
- In case of engine oil, the oil for cold season is recommendable(SAE 0W-5W, etc).

<Tips for starting in the strong electricity place>

If the vehicle does not start in the strong electricity place, put the Smart key near antenna position(center cover) and start the vehicle. If the vehicle does not start, move the vehicle or putting the Smart key near the vehicle, then repeat 2~3 times.

AT STARTING

Fold the main stand.

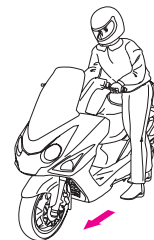

Get on the vehicle.

Mounting should be done from the left side, and should sit squarely on the seat.

Leave either one foot or both feet planted on the ground.

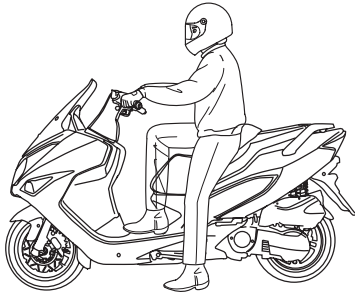

▲ WARNING

- Keep holding rear brake lever before starting.
- After starting, do not increase the engine RPM by force until riding. If the engine RPM increases sharply, the vehicle may start suddenly and occur the serious damage due to like collision, etc.

Start the engine (refer to the engine starting method).

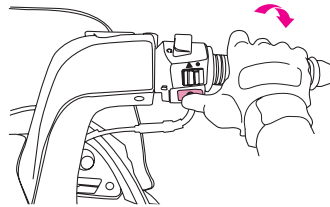
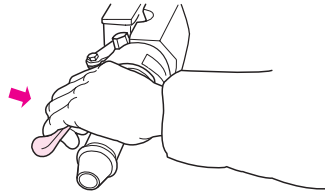

▲ WARNING

- Do not increase the throttle grip sharply.
If the engine RPM increases suddenly highly, it will cause the vehicle to move suddenly forward and cause the serious damage.

Release the squeezing tension on the rear brake lever and slowly begin to rotate the throttle grip to allow for a slow and easy start.

If rotate the throttle grip suddenly, it may cause the vehicle become suddenly accelerated and started.

Then, be sure to start smoothly and slowly.

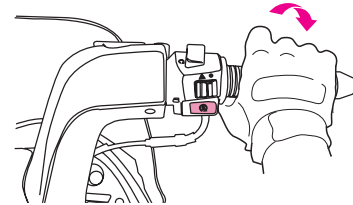

▲ WARNING

- Be sure to check whether the brake releases or not by checking the brake lever.
- The sudden starting, stopping effects badly to vehicle, and even unnecessary fuel consumption.
- Because humidity inflows to the throttle cable causes cold or rust, this results in cable caught. Then, before starting, be sure to check the vehicle regular operation. If the engine RPM isn't decreased after the throttle grip return to its original position, stop operating and inspect it in the closest authorized repair shop.

PROPER DRIVING METHODS

Before entering traffic, use the correct turn signal to forward other drivers of your intentions.

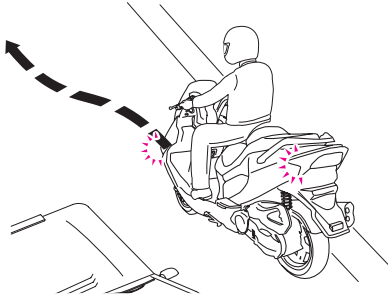

⚠ WARNING

- If the back mirrors are not installed to the vehicle, when changing road lane, the rider may not see well backward then this causes the collision with other vehicle to happen death or serious body damage.
- Before starting, be sure to push aside the side stand. If riding at the side stand stood up, in the curve, the vehicle may touch the ground. This causes the vehicle's turn over and serious damage to the rider.

Speed is controlled by the operation of the throttle grip.

If the throttle grip is rotated...

The speed of the vehicle increases. Please rotate the throttle grip slowly. When climbing a hill, the throttle grip need to be rotated further to give the vehicle more power (Refer to P.43 "Riding a hill")

If the throttle grip is allowed to rotate back...

Speed decreases. This can be done slowly or quickly, depending on how quickly you need to decelerate.

ROTATE

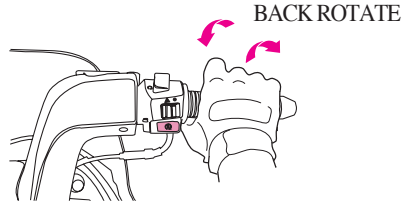

⚠ CAUTION

- At high speed, the lower side of the vehicle may touch with the ground in speed bump, then it may cause the vehicle's turn over. Then, when passing the speed bump, please decrease the speed and pass.
- This vehicle is designed to ride on-road. If riding in steep path of mountains, because of serious trembling of the vehicle, the cables and wire break away from the clamp and cause the accident.

Work the front and rear brakes together.

Allow the throttle grip to rotate back to its beginning position and then squeeze the brake levers.

RR. BRAKE

FR. BRAKE

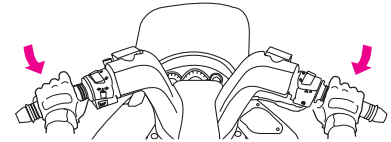

If it is best to operate the brakes by first lightly squeezing the brake levers and then changing to a more firm squeeze.

To stop most safely in a short riding, please grasp the front and rear brakes together.

Normally, for the best braking, the ratios between front and rear brakes are FR:7, RR:3 at the dry road. On rained road or slippery road, FR : 6, RR : 4.

By doing these driving methods, these good driving habits become the brake distance being shorten and the life brakes being extended.

⚠ WARNING

- If using the only one brake, the vehicle may slip aside that causes the death or serious damage.
- If you use the only rear brake, its pad will be worn easily and early then that brings about the bad braking causing the collision accident to result in the death or damage. So, the simultaneous working front and rear brake together is proper and check the brake pad at the periodic checking schedule.

The brakes should never be suddenly applied and the handle bars should never be suddenly turned.

Sudden braking or turning can cause the vehicle to slide and tip over.

It is especially dangerous to perform sudden braking on wet roads or in rainy weather as the tires can lose traction and slip easily.

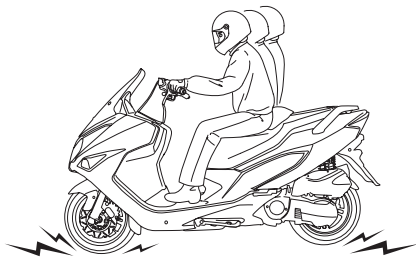

Special care in driving should be taken during rainy weather.

More braking distance is needed when driving on wet roads or in the rain. Reduce speed and be sure to initiate the braking operation sooner than when driving in normal conditions.

On downgrades, allow the throttle grip to rotate back to its initial position to reduce speed, and apply the brakes and drive slowly down the hill.

It is possible for the brakes to temporarily lose operative ability after driving through a puddle or when driving in the rain. To ensure that the brakes are operating properly, slow down (after checking for other vehicles) and while driving slowly, lightly apply the brakes to rid the brakes of any excess water and to dry them.

Be extremely careful when driving in the snow or on icy roads. When driving in these conditions, both the tires lose much of their traction and the rear tire can slip when opening the throttle.

⚠ CAUTION

- At speeding in the rain, water screen phenomenon or slip may cause the turn over of the vehicle.
- In the rain, if the sudden stop or turning on the road lane painted, it may cause the turn over of the vehicle.

STOPPING

When approaching the desired stopping area. Activate the proper winker, and after checking for other vehicles, slowly turn into the area in which you want to stop.

Allow the throttle grip to rotate completely back and apply the front and rear brakes. The brake light will shine to alert vehicles in back of you that you are stopping.

RR. BRAKE



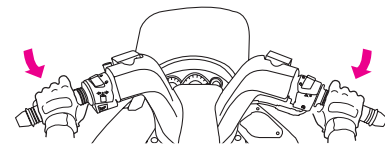

FR. BRAKE

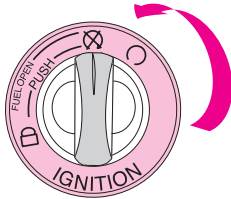

After the vehicle has come to a complete stop. Return the winker switch to the center position and turn the main switch to  (OFF). This will turn the engine off.



CAUTION

- Do not rotate the main switch key while driving. If the main switch is turned to an  (OFF) or  (LOCK) position, the electrical system will not operate.
- Operating the main switch key while driving can be very hazardous. Only turn the main switch  (OFF) or  (LOCK) position after completing stopping the vehicle. Otherwise, the battery may be discharged early. Regardless of smart key, the vehicle can be started by other person and can be theft.

Dismount on the left side and lower the main stand on a flat surface.

Be sure to park in an area that is free of traffic. Also, the vehicle can top over if the main stand is not placed on a stable and flat surfaces.

The main stand is lowered by grasping the handle bars with the left hand, holding the rear carrier with the right hand, and stepping firmly on the stand with the right foot. In this position, lift the rear carrier upward, which will secure the main stand.

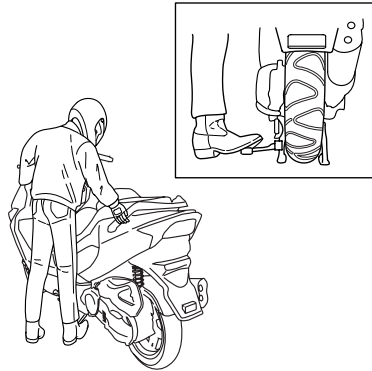

To prevent theft, be sure to lock the steering when parking, and do not keep the Smart key in the vehicle and be sure for the rider have to keep because the vehicle being theft. Also, the using of chain lock as subsidiary thing.

CAUTION

- Park in a safe area that will not block traffic. When you parked the vehicle after driving, make sure foot the vehicle beyond man's reach because engine and muffler are still hot.
- Park the scooter on firm, level ground to prevent it from falling over.
- If you must park on a slight incline, aim the front of the scooter uphill to reduce the possibility of rolling off the side stand or overturning.

DRIVING IN A SLOPING ROAD

The driving in a sloping road needs the engine high RPM, then on the steep place, frequent driving may cause the engine hard worked and early heated, then the engine performance may get lower.

The maximum angle of driving in a sloping road is 16°, (based on one passenger), in case of many driving on that condition, it may the engine being hard worked.

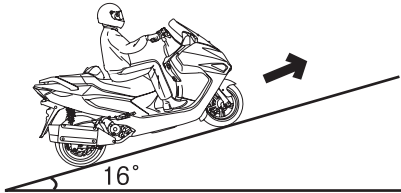

⚠ CAUTION

- If driving over the maximum sloping road or loading heavy baggage, it may cause the engine being early heated or the rider to have difficulty to drive, also when the vehicle turned over, the rider may get serious damage.

If starting from steep sloping road or when starting again after stop, a little bit sudden (rapid) rotating the throttle grip not slow rotating is recommendable.

If so, by preventing the slip of automatic transmission and side worm, the life of engine can be extended and the performance of that can be done at maximum.

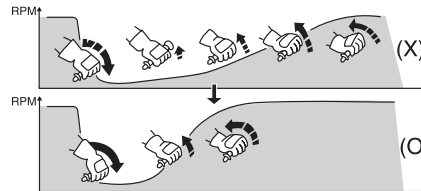

The rapid manipulating of the throttle grip is necessary.

SELF INSPECTIONS BEFORE OPERATION

Inspect by yourself the vehicle and have regular maintenance inspections for increased safety and the prevention of accidents. Regular maintenance inspections should be performed even if the vehicle has not been used for a long period of time.

Self inspections before operation should be performed on a daily basis prior to operating the vehicle.

Inspections of concerned positions of the vehicles.
Brake inspection(the free play of brake free play)
Quantity of brake fluid
The tire air pressure, crack, damage, unusual worn, metal fragment, stone and other alien material and the depth of tire home.
Engine oil(quantity, the leakage)
Quantity of gasoline
Lights and winker inspection
Back mirror inspection(contamination or damage)
Throttle grip operation inspection
Engine starting
Low speeding or accelerating

INSPECTION OF SUSPICIOUS AREA OF THE VEHICLE WHEN DRIVING IN THE PREVIOUS DAY

- Are there any suspicious area of the vehicle in the previous day ?
- If yes, be sure to get the inspection and after repair, to ride the vehicle.

BRAKE INSPECTION

[BRAKE LEVER FREE PLAY]

The proper free play of the brake lever shall be necessary.

Lightly squeeze the brakes levers until the tension is felt to check for an appropriate amount of free play. No free play in the brake levers or overly loose brake levers are indication of a problem in the brake system.

BRAKE LEVER FREE PLAY	10~20mm
-----------------------	---------

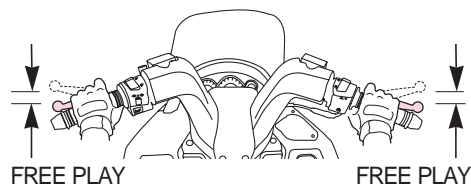

CAUTION

- Specified brake lever free play must be maintained. Excessive free play may cause long braking distance, brake operation faulty and slow reacting time resulting in the dangerous situation and insufficient free play may cause short braking distance and damage brake system(pad, lining, etc)

[CHECK OF BRAKE FLUID OF FRONT / REAR BRAKE]

This is checked by placing the vehicle on its main stand on a flat surface place. Make sure that the handle bars are at a horizontal level. Check to see if the fluid is below the LOWER level.

If brake fluid is significantly low, this may indicate that there is leakage in the brake system. Inspect the brake hose to check whether being leaked.

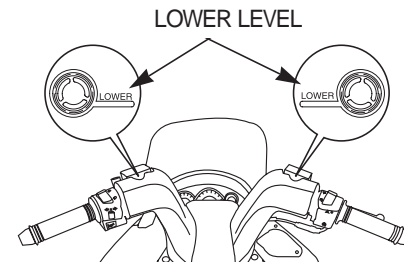

⚠ CAUTION

- If the brake fluid reduces prominently below the lower limit, the braking power may get lower that this occurs accidents. Then, please inspect the brake fluid as well as whether the brake pad of front / rear worn or not.
- If the brake hose being heated, being aged, torn because of the tire interference, the braking may cause be impossible and collision accident that happen serious damage or death. Then, regular inspection shall be necessary.

TIRE INSPECTION

[AIR PRESSURE CHECKING]

Check for an appropriate level of air pressure by examining how the tire sits on the ground. If you notice any abnormalities in the shape of the tire with regard to the area contacting the ground, use a tire gauge to check the tire pressure and adjust the tire pressure to the appropriate level.

TIRE PRESSURE (kgf/cm ²)	WITH ONE PERSON	FRONT	2.00
		REAR	2.40
	WITH TWO PERSON	FRONT	2.00
		REAR	2.50

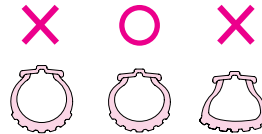

[CRACK/DAMAGE]

Check tire tread and side of crack and damage.

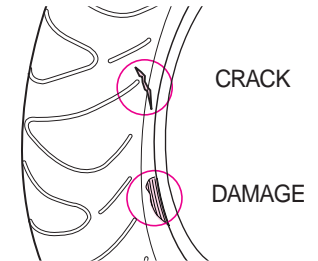

[ABNORMAL WORN]

Check whether there is abnormal worn on the tread of tire or not(side worn, etc)

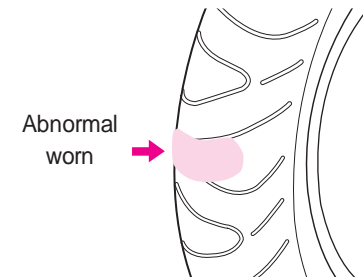

[FOREIGN MATERIALS]

Check tire tread and sides for nails, rocks, etc. That might have become wedged in the tire.

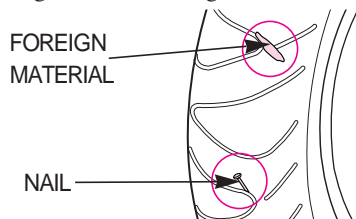

[TREAD DEPTH]

Check the wear indication(wear limit marking) to see if there is an insufficient amount of tread remaining.

If the indicators are visible, replace this with a new one.

WEAR INDICATOR(WEAR LIMIT MARKING

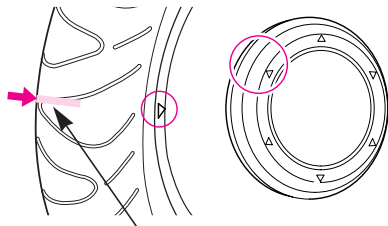

WEAR INDICATOR LOCATION MARKING

⚠ CAUTION

- If air pressure is inadequate or if there are cracks, damage or abnormal wear on tires, it may cause trembling steering wheel and flat tire.
- Insufficient air pressure may cause the heavy steering wheel making handling difficult, fuel over consumption and the excessive wear of tire outer area and excessive air pressure may cause easier wheel handling and lower fuel consumption. But it may also cause the excessive wear of tire center area.
- This vehicle is equipped with tubeless tires. If you have flat tires, please contact authorized maintenance shops for inspection.

FUEL CHECK

[CHECK]

Check gasoline to see if there is a sufficient amount of gasoline to reach your destination.

Place the main switch to \odot (ON) position.

If the fuel meter needle indicates E mark(red position), replenish fuel tank with gasoline as soon as possible.

RESERVE FUEL CAPACITY : 1.9 L

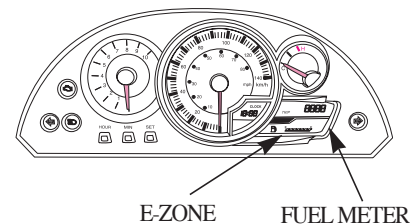

[REFUELING]

Press the main switch lever and after certificating the Smart key, turn the lever to the left, then the fuel tank cap cover will open.

Turn the fuel tank cap to the left, it will open.

Fill the tank with gasoline until it reaches the bottom of the level plate.

When closing, close the fuel tank cap to the right tightly and fuel tank cap cover.

FUEL TANK CAP FUEL INLET

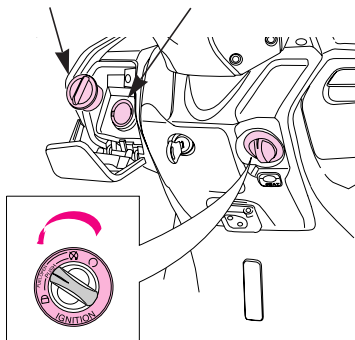

⚠ CAUTION

- Gasoline is extremely flammable and is explosive under certain conditions. Refuel in a well-ventilated area. Make sure to stop engine and stay away from fire when refueling.
- Do not replenish gasoline over the level plate. Gasoline may leak out of the fuel tank when replacing the fuel tank cap if too much gasoline is put in the fuel tank.
- Don't fill low or similar low grade gasoline. Using it can cause damage (bending, getting worn, etc) to combustion chamber and parts of fuel.
- If filling water or oil to the fuel tank, be careful that the engine does not start.
- Do not close the fuel cap with excessive strength. It may cause the damage of the cap the rubber packing resulting in the leak of fuel and may cause fire in case of electrical short or the overturn of the vehicle.
- Filling fuel shall be done in the gas station and do not use the fuel being kept for the long time like in large capacity vessel for fuel. If you use the fuel being stored for the long time, this may cause the clogged of injector, the corrosion of fuel tank and finally bring out bad starting of the vehicle.

ENGINE OIL LEVEL CHECK

Stand the scooter by its main stand on level ground and check the capacity and contamination of oil.

◀ CHECK THE OIL LEVEL ▶

Check the engine oil level each day before riding the scooter.

The oil level must be maintained between the upper and lower level marks on the sight-glass.

If the oil level is close to the lower lever, refill the oil close to the upper level.

Full capacity of oil	1.3 L
Exchange capacity of oil	1.1 L

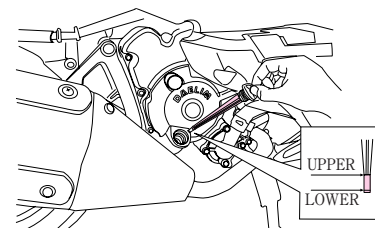

LIGHT / WINKER INSPECTION

[HEADLIGHT, TAIL LIGHT]

Start the engine and operate switches whether the lights turn on or not, and simultaneously check whether the lens of lights being contaminated or not, whether they are damaged.

⚠ CAUTION

- The lighting head light emits very hot heat. If you touch with naked hand, it may be burned.
- When replacing head light lamp, stop lame and winker lamp, use only a bulb of rated capacity. Using a lamp exceeding the rated capacity can cause over-discharge of battery and wire burning. It can lead a fire.
- If the head light is turned off due to aging while driving at night, it will cause an accident by obstructing driver's view. Check the condition daily.
- If the tail light is off while driving at night, it will cause an accident by failure of notice by the other drivers. Check the condition daily.

[INSPECTION OF WINKER]

Turn a main switch ○ (ON). By operating winker switch, check whether the front-rear-left-right lamps are exactly operated or not, and simultaneously the

operating sound of winker works or not

In addition, check whether lens are dirty or damaged (cracked) or not.

INSPECTION OF STOP LAMP

Turn a main switch ○ (ON). Check a stop lamp for proper operation by operating the front wheel and the rear wheel brakes, and also a lens for damage or contamination.

BULB REPLACEMENT METHOD

Be sure to turn a main switch ⊗ (OFF) prior to replacing of a bulb.

Use only a bulb of rated capacity.

After replacement with new bulb, check for proper operation.

⚠ CAUTION

- Care is to be taken to avoid leaving fingerprints on a headlight bulb. Failing to observe this may cause early damage of the headlight bulb resulted from concentration of heat.
- Be sure to wear clean gloves when replacing a bulb. If touched to it with bare hands, clean it with a cloth soaked with alcohol to prevent from early damage.

[REPLACEMENT OF HEAD LIGHT BULBS]

Loosen 4 socket bolts and remove the windscreen. Untie 7 tapping screws and remove the front cover. Untie 8 tapping screws and 2 bolts and remove the front under cover.

SOCKET BOLTS



WASHER BOLTS



TAPPING SCREWS

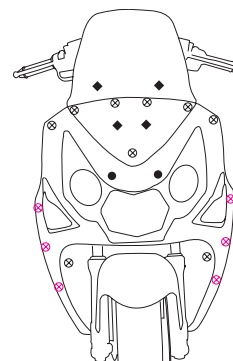

BLACK : FRONT ASSEMBLY
RED : REAR ASSEMBLY

Pull the headlight socket and remove it.
 Remove the rear cover.
 Untie steel wire and remove the head light.
 Replace with the new bulb.

HEAD LIGHT BULB	60/55W, H4
-----------------	------------

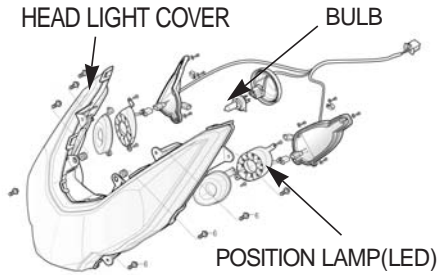

<REPLACEMENT OF POSITION LAMP (LED)>

Untie 4 screws and remove the position dust cover.
 Untie 2 screws and remove the position lamp.
 Remove the position lamp coupler and position lamp(LED).
 Replace with the new position lamp(LED).
 Assemble in the reverse order of disassembly.

<THE ILLUMINATION ANGLE OF HEAD LIGHT>

By adjusting the adjuster bolt of headlight, adjust its illumination angle.
 By rotating screw, adjust it to up and down.

⚠ CAUTION

- Illumination angle adjusted incorrectly may dazzle a facing driver's eyes or result in difficulty to show the forward.

<REPLACEMENT OF REAR COMBINATION LIGHT>

Remove the luggage box.
 Remove the center cover.
 Remove the rear combination light ass'y.
 Replace with the new rear combination light ass'y.
 Assemble in the reverse order of disassembly.

REAR COMBINATION LIGHT LED	26 LED
----------------------------	--------

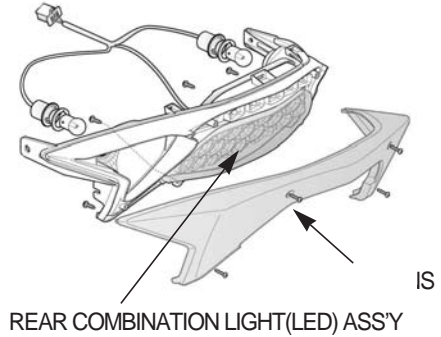

⚠ CAUTION

- At disassembly, be sure not to damage the lens of tail light.
- At replacing the lens of tail light, assemble correctly the lens seal.

[REPLACEMENT OF WINKER BULB]

< FRONT WINKER BULB >

Dip into a hand under the front cover.

Press smoothly the bulb and rotate it counterclockwise and disassemble it.

Replace with the new bulb, and assemble in the reverse order of disassembly.

FRONT WINKER BULB	12V 10W
-------------------	---------

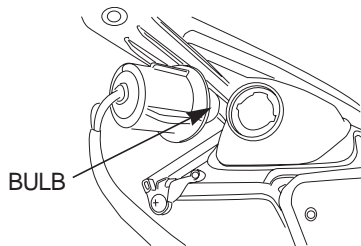

< REAR WINKER BULB >

Untie 2 tapping screws and remove the rear winker lens.

Press the bulb smoothly, rotate it counterclockwise and disassemble it.

Replace with the new bulb, and assemble in the reverse order of disassembly.

REAR WINKER BULB	12V 10W
------------------	---------

WINKER LENS

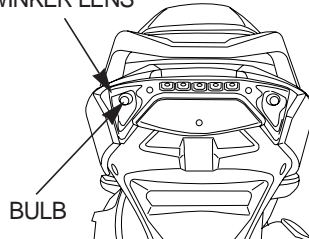

INSPECTION OF BACK MIRRORS

Check the objects at the back are well noticed when seating on a driver's seat, and also mirror for damage or contamination.

FUEL LEAK INSPECTION

Check there is no gasoline leakage from fuel tank, hoses, carburetor, etc.

INSPECTION OF CONTAMINATION OR DAMAGE OF LICENSE PLATE

Check whether the license plate being contaminated or damaged.

To check complete assembly of license plate, touch it by hand and check.

INSPECTION OF COOLING WATER

Stand the vehicle onto the flat ground by main stand.

Open inner box lid in right side of inner box, check whether the capacity of cooling water is within the specified range (between the upper and lower level). If the cooling water is under the lower level, refill water to the designated level.

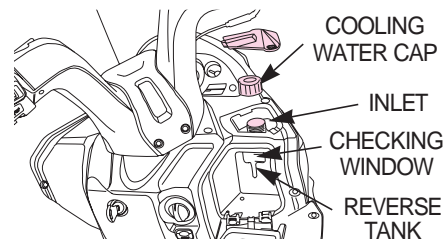

COOLING WATER CAPACITY	1.5L
------------------------	------

⚠ CAUTION

- If the cooling water capacity is under the designated level, check on leakage of cooling water (from engine, radiator, hose, etc)

MAINTENANCE SCHEDULE

Perform self inspections before operation at each scheduled maintenance period.

I: INSPECT AND, CLEAN, ADJUST, LUBRICATE OR REPLACE IF NECESSARY

R: REPLACE L: LUBRICATE C: CLEAN

ITEM		FREQUENCY		ODOMETER READING(NOTE1)					REMARK
				0.5Km	4Km	8Km	12Km	16Km	
				1Month	6Month	12Month	18Month	24Month	
★	FUEL LINE		I	I	I	I			
★	THROTTLE OPERATION	I	I	I	I	I			
	AIR CLEANER ELEMENT		R	R	R	R		Frequent check is recommendable at the places where there are much dirt or humidity	
	SPARK PLUG	I	I	I	I	I		Replace when checked and necessary	
★	IDLE OPERATION	I	I	I	I	I			
	ENGINE OIL	R	R	R	R	R		Depending driving mode, this can be changeable much.	
	COOLING WATER CHECK	I	I	R	I	R		If necessary, replace or refill	
	OIL FILTER SCREEN	C	C	C	C	C			
★	TRANSMISSION OIL	I	I	I	R	I			
	BRAKE FLUID	I	I	I	I	R			
★	VALVE CLEARANCE	I	I	I	I	I		Replace when checked and necessary	
★★	THROTTLE BODY			I		I		Replace when checked and necessary	
	CVT DUST COVER ELEMENT	I	I	I	I	I		Replace when checked and necessary	

ITEM	FREQUENCY	ODOMETER READING(NOTE 1)					REMARK
		0.5Km	4Km	8Km	12Km	16Km	
		1Month	6Month	12Month	18Month	24Month	
	BRAKE PAD WEAR	I	I	I	I	I	
	BRAKE SYSTEM	I	I	I	I	I	Master cylinder,Caliper
★	BRAKE STOP SWITCH		I	I	I	I	
★	HEADLIGHT ADJUSTMENT	I	I	I	I	I	
★	SUSPENSION		I	I	I	I	
★	BOLTS, NUTS, FASTENERS	I	I	I	I	I	
★★	WHEELS / TIRES	I	I	I	I	I	
★★	STEERING	I	I	I	I	I	
★	DRIVE BELT		I	I	I	I	
★	WEIGHT ROLLER		I	I	I	I	
★	SLIDE PIECE		I	I	I	I	

- ★ If you do not have the appropriate tools or information to conduct maintenance, or if you feel you are not capable to perform maintenance on this vehicle, contact authorized dealers or repair shops for maintenance and repairs.
- ★★ To ensure safety, inspections and maintenance of these parts must be carried out by dealers, or repair centers.

NOTES : (1) At higher odometer readings, repeat at the frequency interval established here.

(2) Service more frequently when riding in unusually wet or dusty areas.

(3) Replace every 2 years, or at indicated odometer interval, whichever comes first. Replacement requires mechanical skill.

SIMPLE MAINTENANCE

This section is an explanation of correct inspection methods about the result of vehicle inspection, cleaning, adjustment, replacement, etc. Please always refer to this section when wanting to inspect or repair your vehicle.

⚠ CAUTION

- Always observe safety rules when performing maintenance on the vehicle
- Choose a flat ground and make sure the main stand is in a secure down position
- The maintenance shall be at ⓧ (OFF) of main switch lever.
- Be careful about burnt because there happens heat in muffler, engine when doing maintenance right after engine stop.
- After self maintenance, the waste material (replaced parts, antifreeze, oils, etc) must be packed in the specified container and entrusted disposal to the authorized disposal company.
- In case of wires, if do not use the designated specification of them, the over current may happen that cause melt the covering material then happen fire at current short if there is inflammable material.
- At self maintenance, if the alien material may come inside, because of engine stop and the over tum of the vehicle, these may occur a serious damage.
- At self maintenance, if being put hand or leg into the wheel rolling, it may cause serious damage,
- If the grease is stained with drive belt, because of slippery, it may cause bad power operation and make noise.

REPLENISHING FRONT, REAR BRAKE FLUID

Clean dust and other foreign materials around reserve tank to prevent foreign materials from falling inside tank.

Untie screws, oil cup cap, middle covering, diaphragm plate.

Replenish the recommended brake fluid to the upper level of reserve tank.

After replenishing brake fluid, at re-assembly, be careful about being chewed to the assembly way of diaphragm. And tighten cap by the screws completely.

RECOMMENDED BRAKE FLUID

DOT 3 OR DOT 4

⚠ NOTE

- At replenishing brake fluid, be remind of the brake pad worn.
If the brake pad is seriously worn, the height of reserve tank fluid may get lower.

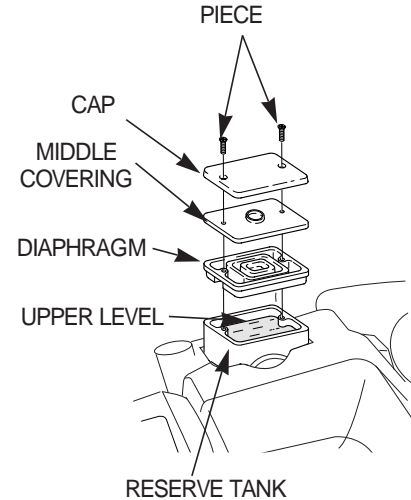

⚠ CAUTION

- When replenishing the brake fluid, be careful that dirt or water, etc attached to reserve tank is not mixed. If mixed, because getting the brake power lower, it may cause accident.
- Do not replenish the brake fluid not to over the upper level. If so, the brake fluid coming out may cause touch with the outer covers. It may cause the damage or crack of these covers. Also, if the brake fluid is stained to eye or skin, it may cause eye blind and fatal damage. If being stained with brake fluid, wash cleanly with water right now.
- To prevent the chemical change, use the designated brake fluid(DOT3 or DOT4).
- If the capacity of brake fluid is a little, that means something wrong in the brake system.
- Then, please visit and ask the nearby service station to solve.
- If the wasted brake fluid or asbestos pad are thrown away to the designated place, it may cause the environmental contamination that affect the lawful sanctions.

BRAKE HOSE, PIPE LEAKAGE, DAMAGE, ASSEMBLY STATE

Visually check for fluid leakage or damage and, using a spanner, check joints and clamps for clearance. Also, check hose and pipe protective parts to see if they contact other parts when turning the handle bars or due to vibration when driving.

FRONT, REAR BRAKE PAD

Brake pad wear depends upon the severity of usage, the riding mode, and road conditions. (Generally, the pads will be worn faster on wet and dirty roads.)
Inspect the pads at each regular maintenance interval.

⚠ WARNING

- If the worn status of pad exceeds over the abrasion limit, the braking power becomes lower prominently or it can not be done. Then, because of this, die or serious injury by collision may happen.

[FRONT BRAKE]

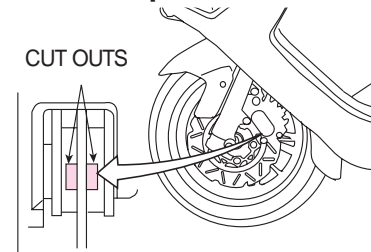

[REAR BRAKE]

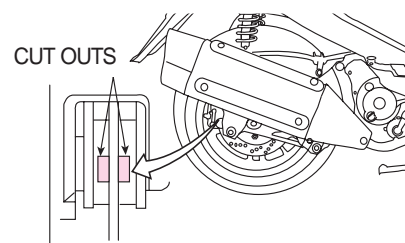

CHANGING ENGINE OIL

When the engine oil is contaminated, the life of engine will be remarkably shortened. Keep the proper engine oil level, kind and replacing period.

Place the vehicle on a flat surface, and idle(warm up) the engine 2~3 minutes.

Stop the engine, separate the engine oil level gauge, place a vessel under the engine, remove the oil drain bolt to drain the oil

Remove the tappet adjusting hole cap, and clean the oil filter screen.

Check the seal rubber of oil filter screen, the O-ring.

Install the oil drain bolt, assemble the oil filter screen, spring, tappet adjusting hole cap.

At replacing the oil, add the engine oil by opening the oil level gauge in RH. Crank case cover.

At adding the oil, check the oil level gauge and re-fill it near to the upper level.

WHEN CHANGING OIL : 1.1 L

TOTAL CAPACITY OF THE OIL : 1.3 L

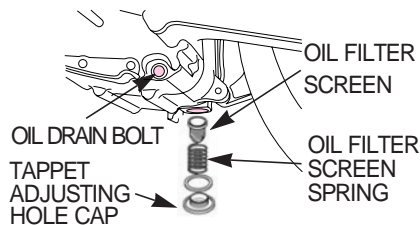

[SPECIFIED GENUINE OIL]

Don't fill the low grade oil. Using it can cause damage to engine, and can't receive the warranty.

Use only the genuine oil. Genuine oil :

MOTIX 4 oil

SL grade(SAE : 10W/40)



CAUTION

- If changing the oil by loosening the oil drain bolt, disassemble the tappet adjusting hole cap surely and clean the oil filter screen.
- Right after the engine stopped, because the engine oil already being heated, be careful about to be burnt at replacing the new engine oil.
- When refueling, make sure not to enter the dirt or dirty material into oil pouring port.
- If the oil overflows, wipe it cleanly.

CAUTION

- When changing the engine oil immediately after stopping the engine, be careful not to be burnt the heated oil.
- Don't fill the low grade oil. Using it can cause the damage to engine and parts. If the engine is stuck while traveling due to this, it may lead death or serious injury. Use only the genuine oil.
- Do not pour the 2 cycle engine oil. Using it can cause serious damage to engine. If the engine is stuck while traveling due to this, it may lead death or serious injury.
- If the tire is stained with oil while or after refueling, the vehicle may slip while traveling to cause roll over.
- Do not discard the engine oil other than specified place. It will bring environmental contamination, and be brought under the law.

FRONT, REAR BRAKE PAD

[CAPACITY OF TRANSMISSION OIL]

Stand the main stand on a flat place, 2~3 minutes later after stopping the engine, disassemble bolts, check the transmission oil capacity whether it is placed to the hole of check bolt.

If the surface of the oil is lower than the hole of check bolt, replenish the oil until the oil coming out from the hole of check bolt.

After replenishing, assemble the check bolt completely.

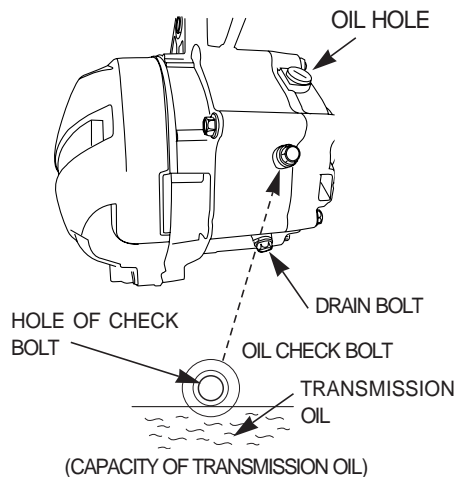

[RECOMMENDED OIL]

RECOMMENDED OIL : SAE80W-90

CAPACITY OF TRANSMISSION OIL	0,15 L
------------------------------	--------

⚠ CAUTION

- When replenishing the transmission oil, be careful that alien material (rubber, etc) does not come into the oil pouring port.
- Regardless more or less of the transmission oil compared with the specified capacity, it may give bad effect the engine or transmission.
- Surely use the specified transmission oil. If not, it may change quality overtime and cause damage to the vehicle.

[OIL LEAK]

Check to see if transmission oil leaks out from transmission case or check bolt.

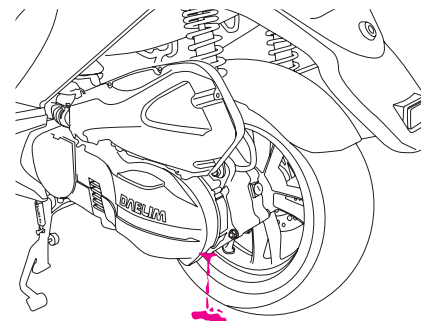

COOLING WATER REPLACEMENT

- Open the right side inner cover lid.
- Disassemble the Reserve Tank Cap.
- Untie the drain bolt of water pump and discharge cooling water.
- By leaning the vehicle to the right, discharge cooling water.
- Assemble the drain bolt.
- Refill the cooling water to the reserve tank.
- Start the engine, remove air and check whether the level of cooling water is stable.
- Assemble the reserve tank cap.

FULL CAPACITY OF COOLING WATER : 1.5L

* The recommended antifreeze : LG-Caltex oil, CX/AF cooling water antifreeze EQUIV 40%

⚠ CAUTION

- Stop the engine operation and wait by the time when the engine cools down enough.
- Regarding the replacement of cooling water, because it is improper for untrained person to replace, request to the professional technician or mechanic.

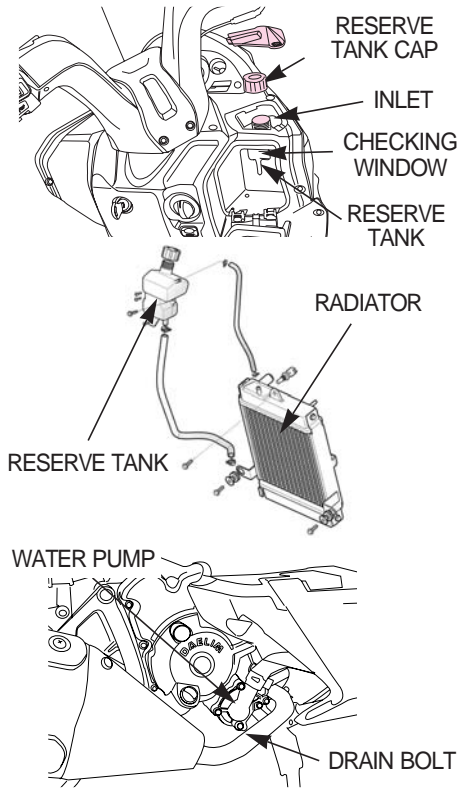

SPARK PLUG

If electrode is stained or its clearance is not right, satisfactory spark is not made. Clean and make adjustment.

- Remove center cover
- Remove spark plug cap
- Clean around the spark plug
- Pull out the spark plug by plug wrench

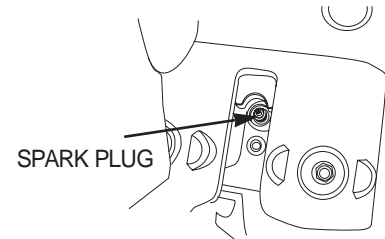

- Clean plug with plug cleaner
- Check electrode for being worn or corroded. If the ends become round, replace it with a new one.
- Check the plug gap using a feeler gauge.

PLUG GAP : 0.8~0.9mm

Tighten with hands until the plug washer touches cylinder head.

STANDARD PLUG : CR8EH-9

If new plug is installed, turn 3/4 and tighten it by using a plug wrench

If plug is reused, turn 1/8 and tighten it.

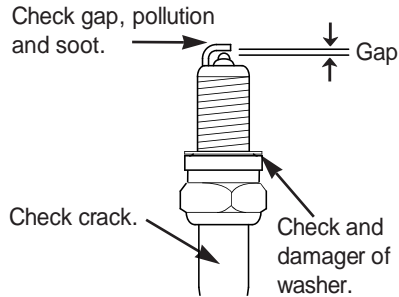

⚠ WARNING

- If plug of different maker or different heat value is used, it causes unsatisfactory engine starting, inadequate engine revolution and output deterioration.
- Be sure to use the standard plug (CR8EH-9) and R(resistance) type plug.
- After driving, the spark plug becomes very hot. When inspecting, pay attention not to be burnt.

CLEANING TERMINALS OF BATTERY

When removing the pillion seat and open the battery cover, you can find the battery.

If the battery terminal(s) is(are) polluted or in-rust, separate battery and clean it.

Battery terminal in rust with white powder should be cleaned with warm water.

In case of serious rust of battery terminal, disassemble the battery cord and grind it with wire brush or sandpaper.

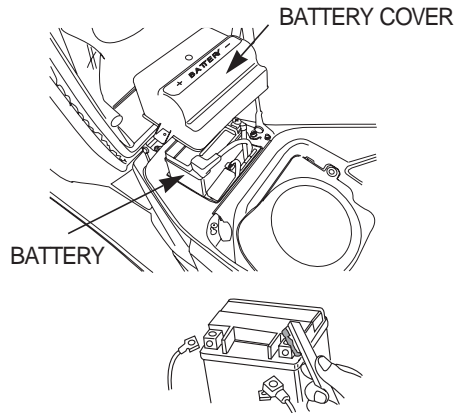

⚠ CAUTION

- Turn the ignition switch OFF before disconnecting the terminal from the battery.
- Disconnect the negative(-) terminal lead from the battery first. When connecting, connect the positive(+) terminal lead first. If you work in reverse order, short circuit will occur resulting in fire.
- Make sure that terminals do not contact with other adjacent parts when handling (+), (-) terminals. Contact with other parts may cause spark resulting in electrical equipment malfunction, fire and electric shock.
- Do not apply excessive impact. When handling the battery, stay away from flammable materials.
- If the electrolyte contact with terminal, it will be corroded earlier.
- The battery is shield type, so do not disassemble the pouring plug.
- When not using vehicle during a long time, take off the battery from the vehicle to keep from self-discharge and electric discharge. Put the battery in a well ventilated place after charging fully. In case it isn't available to take battery off from the vehicle, disconnect (-) terminal.

⚠ CAUTION

- When using the battery without cover, (+), (-) terminals may be connected to cause short circuit resulting in fire. When handling the battery, stay away from flammable materials.
- Your battery is a maintenance-free type so check or refilling of electrolyte will not be required. If there is any abnormal, contact to Daelim service center.
- If you reform the battery for car, battery will be improperly installed to cause short circuit resulting in fire.
- If the electrolyte gets into your eyes or on skin, it'll cause a serious injury.
- Do not discard the battery other than specified place. It will bring environmental contamination, and be brought under the law

FUSE REPLACEMENT

Turn off the main switch to see if the fuse is severed. If the fuse is severed, exchange the fuse into a fuse with same capacity.(15A)

Fuse is installed in fuse holder around the battery.

To change a fuse, first take off fuse holder. Then, remove the disconnected fuse, and insert the reserved fuse with same capacity.

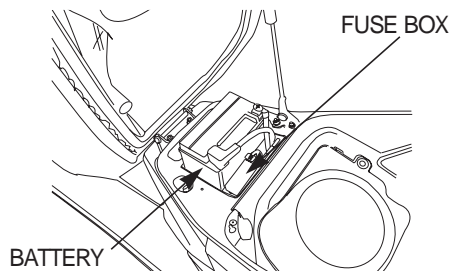

If the fuse immediately becomes severed after being changed with the new one, check another problem of the electric system. Contact to the designated service shop.

(Out of order in the charging system, the wires being taken off, bad connection of connector)

[DISASSEMBLY]

Disassemble by pulling out from the upside

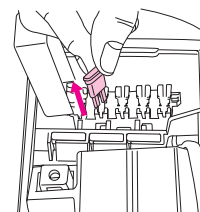

[ASSEMBLY]

Press and assemble from the upside

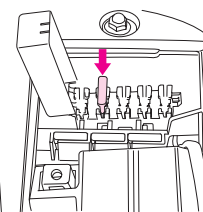

FUSE A	30A	CHARGING, COMBI. SW, REGULATOR
FUSE B	15A	WINKER RELAY, METER LIGHTING, HORN HEAD LIGHT (HI / LOW), FR/RR. STOP SWITCH, TAIL LIGHT, FUEL METER
FUSE C	15A	IGNITION COIL, ECU, OXYGEN SENSOR
FUSE D	15A	ECU, FUEL PUMP RELAY
FUSE E	15A	FAN MOTOR

NORMAL

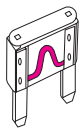

CUT

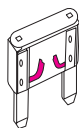

⚠ CAUTION

- At replacing fuse, OFF the main switch. If the main switch is ON, the fire accident may occur because of short circuit.
- Check whether the fuse assembled to the holder moves or not at assembling it. If the fuse assembly is loose, unexpected accident may occur.
- Do not use the over-capacity fuse. Because this may cause the overheating of wires and damage, be sure to never use.
- When installing electric parts (lights, meters, etc), because there are different fuses for various vehicles, this may cause the fuse cut or battery discharge.
- At washing the vehicle, be careful not to wash strongly around the fuse holder.
- In order to remove the fuse, do not use the drivers or metal materials. That may damage the electric parts or equipment due to short circuit, etc.
- After replacing the fuse, if the fuse continuously cut, this means other overload to electric system. Then visit to the designated service shop.

AIR CLEANER ELEMENT INSPECTION

<REMOVAL>

Loosen the 6 screws assembling the air cleaner case cover and remove the tube clip and air cleaner case cover.

Disassemble the air cleaner element and inspect it.

If the air cleaner element is excessively dirty or damaged, replace it with the new one.

Assemble correctly air cleaner element and seal, then assemble air cleaner cover.

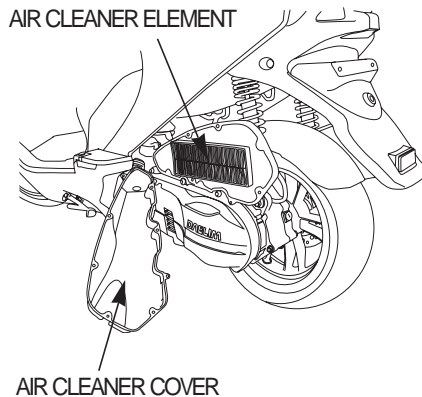

⚠ CAUTION

- If the air cleaner element is inadequately assembled, dust and other waste materials can directly enter the engine. This results in increased cylinder wear and reduced power, and reduced durability of the engine.
- When washing the vehicle, be careful not to allow water to get into the air cleaner. Difficulties in starting the engine may result if this happens.
- If the engine start is failed during rain or after driving across water pool, check to see if the water is infiltrated in the air cleaner and clean it.
- Do not drive in the flooded area. If the water enters the air cleaner or engine, the vehicle may be subjected to the rear-end collision due to the power failure.

CVT DUST COVER ELEMENT INSPECTION, CLEANING

<DISASSEMBLY>

Untie 2 bolts in LH. Crank Case Cover and disassemble CVT DUST COVER ASS'Y.

Disassemble CVT DUST UPPER COVER, ELEMENT and check.

If the Element gets dirty because of dirt, alien material, clean it.

Assemble in the reverse order of disassembly.

LH. CRANK CASE COVER

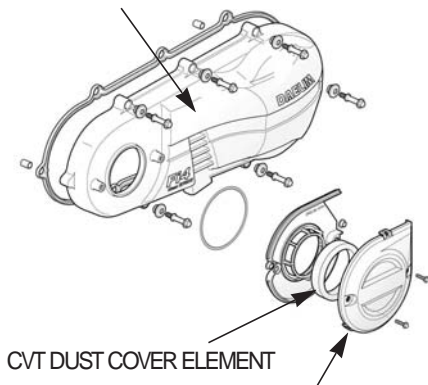

CVT DUST UPPER COVER

CABLE RUBBER PART INSPECTION

A rubber boots is assembled on the cable to protect the inner cable.

Make sure that this part is placed firmly around the correct part of the cable. When washing the vehicle, do not directly spray water on to the rubber boots or scrub it with brush. Use a dry cloth to clean this area.

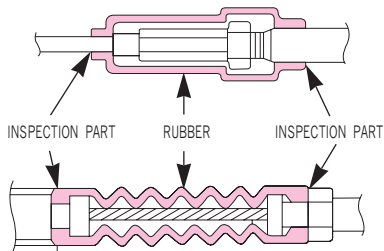

Check the installing condition of rubber boots daily. After adjusting the free play of throttle grip, never forget to place the rubber boots to the original position.

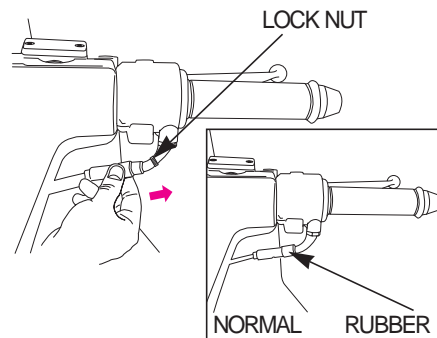

WARNING

- Infiltration of the foreign materials or water caused by damage of rubber boots (disengagement, tearing, etc.) may cause freezing in winter season resulting in faulty operation. It may lead death or serious injury by decreasing of sudden acceleration and braking force due to engine rpm.
- If any damage is found, replace with the new one immediately.

SIDE STAND INSPECTION

Erect main stand and place vehicle in upright position on level ground. Check the spring for damage or loss of tension and the side stand assembly for freedom of movement.

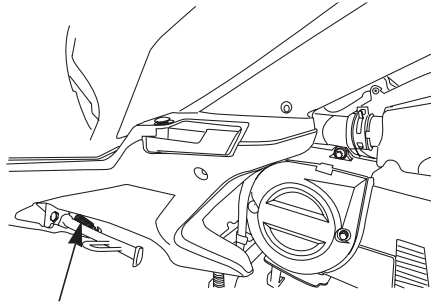

SIDE STAND SPRING

CLEANING

Make sure to stop the engine prior to vehicle.

Be careful not to allow water to enter the muffler during the washing. Water inside the muffler may cause an improper engine starting or rust occurrence.

Do not let water get inside the braking system during the washing, as water inside the brake system may weaken the braking power. Upon completion of washing, select a safe place where there is no traffic obstruction, and start the vehicle.

Lightly apply the brake while driving at a slow speed and check the braking power. If the braking power has been weakened, apply brake lightly while driving at a slow speed to dry up the brake system.

Take precautions when waxing the vehicle. Excessive polish of the painted section and/or the resin part with compound wax might damage the painted section causing discoloration of the affected area.

At washing, be careful for water not to flow into the trunk(luggage box). At inflowing, the valuable things inside trunk can be wet.

CAUTION

- At washing, if welding point of cable gets rust because water inflow, starting can not be done.
- At washing, if water inflows to the muffler, the muffler gets rust early and damaged that may cause bad starting.
- If washing by strong alcohol detergent, it may cause the lamps and plastic parts being damaged or discolored.

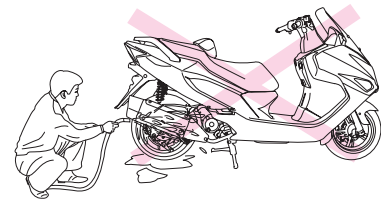

Q2 INSPECTION SEET

- In order for safe scooter driving, always maintain healthy condition of the vehicle. This inspection sheet includes how to check and maintain the vehicle, says about its heath care and maintenance.
Be sure to read fully and keep in mind the inspection contents. Also, please care for the inspection result that shall be written.
- The claims and defects without daily, regular inspection and not done according to our designated inspections will be exempt from the warranty.

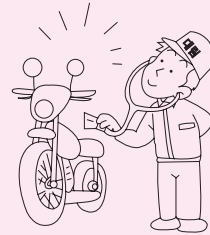

DAILY INSPECTION(BEFORE DRIVING)

For safe and comfortable usage of the vehicle, the daily inspection means that you, customer check and inspect your vehicle directly and basically once daily.

REGULAR INSPECTION

The regular inspection means checking points decided based on standard usage of the vehicle and other checking points we designated.

Purchase	1month (500km)	6month (4,000km)	1year (8,000km)	1year 6month (12,000km)	2year
(16,000km)					

CAUTION

- In case that the vehicle is used at other conditions(for instance, like seriously commercial used like for delivery, quick service, etc) not standard conditions, the durability of parts may get wrong compared with the standard usage of vehicle.
- In this case, please visit to the nearby our designated service shop and request, ask about the regular inspection schedule, oil replacement schedule, consumable parts, and so forth.

ABOUT THE REGULAR INSPECTION

The regular inspection and maintenance are in charge of customer.
The regular inspection and maintenance is for the healthy care of the vehicle !

In order for safe driving, the daily and regular inspection and maintenance is essential. The vehicle scooter is composed of many parts and components, then as time passes, the parts' deterioration and abrasion are proceeding.

The regular inspection and maintenance focus on preventing the serious trouble of the vehicle by foreseeing the change of vehicle through checking the vehicle, also are able for the rider to drive safely until next inspection and maintenance.



POINT 1 – OIL

Oils and fluids are used at the many positions of the vehicle.

Oils used to engine, transmission, radiator can keep the vehicle stable performance with lubrication, cooling, preventing rust. Then, because the oils of the vehicle can not cleanly recovered, at regular inspection and maintenance, they shall be replaced or refilling.

Principal oils
Engine oil
Brake fluid
Transmission oil

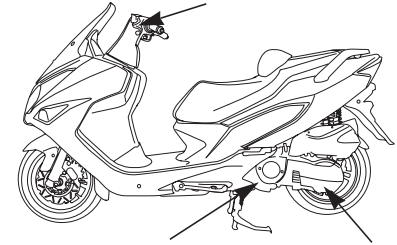

POINT 2 – Rubbers

The rubber is mainly used for parts like hoses, seals.

The aged rubber gets weak and damaged.

Also, the brake hose that transmit pressure is made of rubber. Check its elasticity and being cracked, if necessary replacing, replace with the new one to prevent beforehand out of order of the vehicle.

Principal rubbers
Brake hose
Caliper seal
Fuel hose
Master cylinder
Radiator hose

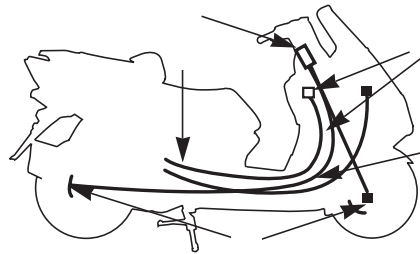



POINT 3 – Abrasive parts

There are many abrasive parts in the vehicle.

There are parts doing their roles by being worn like the eraser. Tire, brakes...

If you use these kinds of parts by that time that they are worn completely, this may cause accident, then, the regular inspection, replacement of parts shall be important.

Principal abrasive parts

Brake pad
Clutch weight shoe
Tire
Weight roller
Drive belt

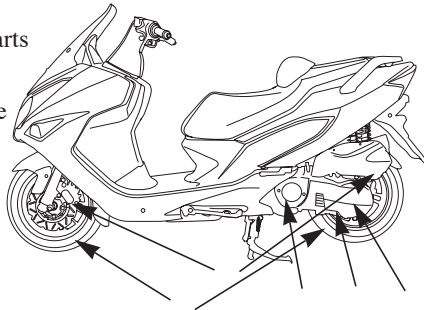

DAILY INSPECTION, REGULAR INSPECTION

At using the vehicle, shall do obligatorily one day once inspection(before driving) and regular inspection for the purpose of safe and comfortable driving.

⚠ WARNING

- Improper repair and maintenance, non-repair and maintenance may cause accident like turn-over of the vehicle or death, serious damage.
- Be sure to do the regular inspection according to this user's manual saying about inspection method, tips.
- Regarding abnormal points, the repair and maintenance shall be done before driving.

DAILY INSPECTION

Daily inspection is that the rider shall inspect his vehicle once daily before driving. As for the detail inspection methods, refer to “ Checking repair and maintenance “ and “ Checking list “ of this manual.

DAILY INSPECTION	
Inspected parts or contents	Inspection details
Brake	<ul style="list-style-type: none"> • Do brake pedal and lever operate well, also braking is good? • Is the capacity of brake fluid proper?
Tire	<ul style="list-style-type: none"> • Is the air pressure of the tire proper? • Is there any place damaged or cracked? • Is there any abnormal abrasion? • Is the depth of tire home enough? ()
Engine	<ul style="list-style-type: none"> • Is the capacity of engine oil proper? () • Does the engine work well or is there any abnormal noise?()
Ignition system and direction signals	<ul style="list-style-type: none"> • Is the ignition or lighting condition good or are they damaged or contaminated?
Abnormal situation at driving	<ul style="list-style-type: none"> • Is there any abnormal situation in relevant points?

REMARKS) In case of * points, please perform at proper time(long driving, washing, fueling) by checking the vehicle driving distance, vehicle driving condition, etc.

RECOMMENDED REPLACEMENT PARTS

Depending upon the vehicle driving distance and time going by, even though there is not outer shape disorder, there are a few parts that are difficult to decide whether they can be used longer or not.

The following parts are those that we recommend to replace regularly to obtain the safe driving of the vehicle. At designated schedule, please do regular replacement. When replacing, visit for advice with the near designated repair shop for the replacement of parts.

The repair and maintenance of regularly replaced parts is done by yourself and paid by yours.

Replacing part names		Replacement schedule	Remarks
		Based on owner's vehicle	
Brakes	Brake fluid	Every 2 years	
	Master cylinder and Caliper	Every 2 years	
Engine oil		Initially 500 km After then every 4,000 km	In case of the vehicle used for mainly off-road, delivery, quick-service, the earlier replacement is recommendable.
Transmission oil		Every 12,000km	Replace when inspected or if necessary.
Spark plug		Every 4,000km	Replace when inspected or if necessary.
Air cleaner element		Every 4,000km	Replace when inspected or if necessary.
CVT Dust cover element		Every 4,000km	Inspect and clean.

STEERING STEM LOCK

For the vehicle performance fully done, it is important to select the proper oil and be used. Please use the designated genuine oil to DAELIM vehicles.

OIL REPLACEMENT AT REGULAR SCHEDULE

The contaminated oil as well as bad one may give bad effect to the engine.
Be sure to replace the new oil meeting at the replacement schedule.

In the below usage conditions, the early deterioration may happen and replace at the earliest time.

- Frequent driving on off-road.
- Repeating of short distance driving
- Frequent usage at idling
- Using at cold area
- Using for the purpose of delivery, quick-service.

Using oils

Engine oil	· DAELIM Genuine oil - MOTIX 4 cycle oil, SL(SAE ; 10W/40)
Transmission oil	· Gear oil · SAE 80W/90
Brake fluid	· DOT 3 or DOT 4
Movable drive face boss grease	· Albania EP2
Cushion	· Oil pressure hydraulic fluid

INSPECTION AND MAINTENANCE

INSPECTION AND MAINTENANCE





Be careful about enough safety at inspection

- Select the flat and durable ground at inspection, erect the main stand then inspect.
- After engine stop, because the engine, muffler and exhaust pipe, and other parts are heated, be careful about burning.
- The emission gas includes harmful components like CO.
- Do not inspect or start at sealed parking lot or not ventilated place.
- If inspection by driving vehicle, be careful enough about the traffic situation.
- When doing inspection and repair, be careful about inflammable things, especially be careful near gasoline and battery.
- If tool or equipment for inspection, repair is necessary, please use the proper ones.
- For the safety, do inspection and repair within yourself know-how and skill.
- If you think that a certain inspection or repair is difficult, visit and consult with the designated service shop.

WARNING

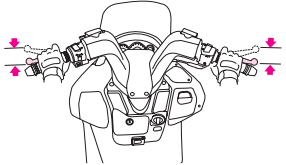
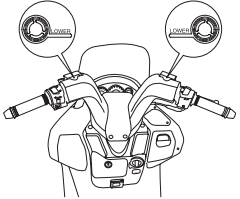
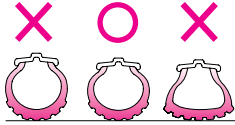
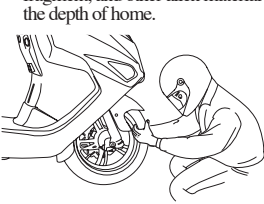
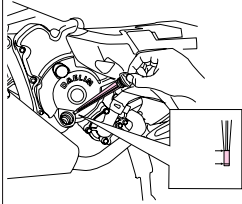
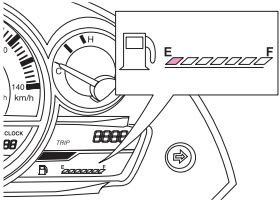
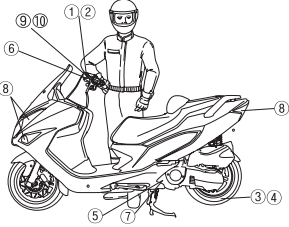
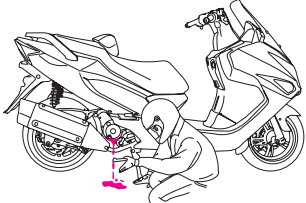
- If you do not observe the proper inspection and repair method, this may occur accident like turn-over, even happen death or serious damage.
- Inspection and repair shall be observed according to the inspection method written on the user's manual.
- Regarding the abnormal contents, be sure to inspect and repair before driving.

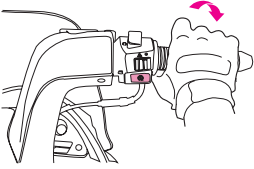
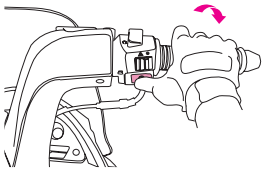
DAILY, INSPECTION CHECKLIST

<p>The free-play of brake lever</p> 	<p>The capacity of brake fluid</p> 	<p>The air pressure of tire</p> 	<p>Tire crack, unusual abrasion, metal fragment, and other alien material the depth of home.</p> 	<p>The capacity of engine oil</p> 
<p>The capacity of gasoline</p> 		<p>Leakage of engine oil, cooling water, fuel</p> 	<p>Lighting system and direction signals</p> 	
<p>Operation of throttle grip(cable)</p> 	<p>Starting performance of engine</p> 	<p>Low speeding, Acceleration</p> 	<p>The vehicle's position being out of order during driving</p> 	

DAILY INSPECTION METHOD

There are little difference depending upon the vehicles.
As for the difference, please refer to each vehicle's user's manual.
If you think that your daily inspection has something wrong,
please visit to near designated service shop and request to repair.

INSPECTION METHOD, TIPS

Brake

- Braking on brake lever free play and it's operation.



If pulling brake lever and you feel it soft, it means that air may mixes in brake fluid. If yes, check the capacity of brake fluid and install the connection area of brake hose or deflate air.

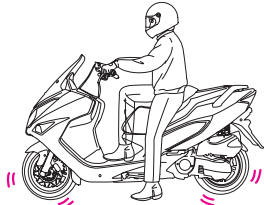

Also, drive the vehicle on the dry road, operate front and rear brake separately to check whether braking performance well done or not.

INSPECTION METHOD, TIPS

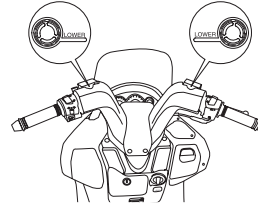

Erect the main stand at flat place, move the steering handle and position the upper side of reserve tank cap horizontally. Or upright the frame and the brake fluid side being flat with level line.

Check whether the brake fluid in brake reserve tank is over the low level.

CAUTION

- Be sure to use the designated brake fluid.
- If not, the brake fluid may be contaminated or cause something wrong of brake system.

TIRE

- Checking of the air pressure of tire



By seeing deformation status of surface of tire, check whether air pressure is enough or not.

If you drive long distance or drive at high speed, the inspection of air pressure by tire gauge is essential.

	1 person	2 persons
FRONT	2.00 kg/cm ²	2.00 kg/cm ²
REAR	2.40 kg/cm ²	2.50 kg/cm ²

INSPECTION METHOD, TIPS

- Checking of crack or damage

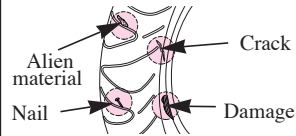

Check whether there is prominent crack or damage around the tire.

Also, check whether nail, stone or alien material stuck to the surface if tire.

- Checking of abnormal abrasion

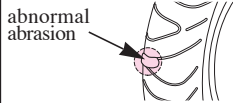

Check whether there is abnormal abrasion on the surface of tire.

- Checking the home depth of tire

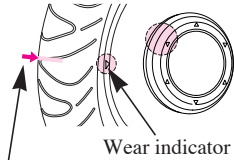

Check by the wear indicator (slip line) whether the home depth of tire is enough or not.

Wear indicator position mark
Wear indicator (shows the abrasion limit)

⚠ WARNING

- The usage of excessively worn tire and tire having improper air pressure may cause accident like turn-over, result in death or serious damage.
- Observe the air pressure shown on the user's manual and replace the excessively worn tire with the new one.

INSPECTION METHOD, TIPS

ENGINE

- Inspection of engine oil capacity ()

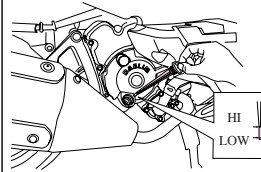

At flat ground, do idling the engine for a few minutes, erect the vehicle and stop it, then check the engine oil capacity whether it is within the specified range of level gauge (between the upper and lower line).

- Inspection of cooling water capacity

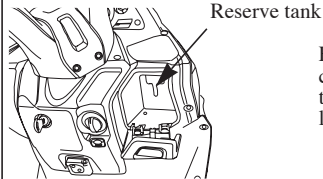

Erect the main stand, check whether the cooling water in reserve tank is within the specified range (between upper and lower line).

- Checking the engine starting and abnormal sound (noise)



Check whether the engine start speedily and then rolls smoothly.

Also, at engine starting, check whether abnormal noise is or not at idling status.

INSPECTION METHOD, TIPS

CHECKING ABOUT LOW SPEED AND ACCELERATION()



Check whether there is something wrong at low speed or accelerating.

LIGHT SYSTEM AND DIRECTION INDICATORS



Turn on the main switch and check whether there is something wrong in head light, tail light, brake light and direction signal's lighting status.

Also, check whether there is contamination or damage of lens.

MAINTENANCE



Check whether there is something wrong causing inconvenience to riding.

INSPECTION METHOD, TIPS

FUEL CAPACITY

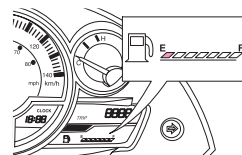

Check whether the fuel gauge at engine start is within the " E " range(red) or whether the main switch is " ON ".

If the fuel gauge is under the " E " range(only one space), do not hesitate to fuel replenishing.

LEAKAGE OF ENGINE OIL, FUEL

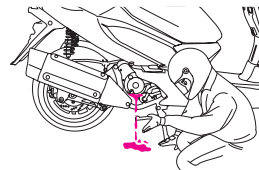

- (1) Check by eye whether the engine oil leaks from the engine.
- (2) Check by eye whether the cooling water leaks from the engine or radiator
- (3) Check by eye whether the fuel leaks from the fuel tank, throttle body.

OPERATING THROTTLE GRIP(CABLE)

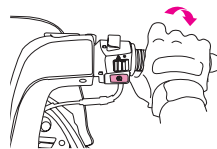

Erect the main stand, start the engine and check whether the throttle operates well or not by twisting or napping.



Especially, on the condition that the throttle grip is napped, check whether the engine RPM goes up improperly.

Remarks) () Inspection is checked on the conditions, driving distance, the situation of driving.

As for other inspections, please do once daily before driving.

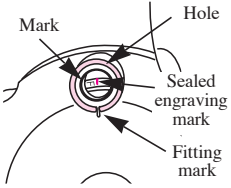
CHECKING POINTS

Checking points	Checking timing	Detail checking contents
Ignition system 1. Spark plug status  <p>Gap</p> <p>Central electrode</p> <p>Earth electrode</p>	6 Mon. (4,000km)	(1) Separate the spark plug, check by eye whether there is the contamination and damage of electrode, the damage or crack of insulator. (2) By using the wire brush or plug cleaner, clean the spark plug and check whether the gap(plug gap) between the central electrode and earth is within the designated range or not, by using plug cap gauge (The gap of spark plug : 0.8 ~ 0.9mm)
2. Ignition timing  <p>Mark</p> <p>Hole</p> <p>Sealed engraving mark</p> <p>Fitting mark</p>	12Mon. (8,000km)	(1) After the engine got warm, check by fitting F mark whether the ignition timing is proper or not, by using timing light at idling.

Checking points	Checking timing	Detail checking contents
Engine 1. Engine starting, abnormal noise 	12Mon. (8,000km)	(1) Check whether the engine operates promptly and works well. (2) At engine starting, check whether there is abnormal noise at idling.
2. Low speed, acceleration 	12Mon. (8,000km)	(1) On the condition that the engine gets warm, check whether the idling is kept continued smoothly or not. (2) When the engine operates slowly, check whether the operation of throttle grip has something or not, or there is no engine stop, knocking and the engine works well.

Checking points	Checking timing	Detail checking contents
<p>3. The status of emission gas</p> 	6 Mon. (4,000km)	<p>(1) On condition that the engine gets warm, check whether the idling RPM is within the designated range, by using RPM tester.</p> <p>(2) Check by eye whether the color of emission gas is white or black.</p> <p>(3) Check whether the vehicle is proper to the emission gas regulation, or at idling, check the capacity of CO and HC by the tester.</p> <p>(Checking contents)</p> <ul style="list-style-type: none"> • The contamination of engine oil, the capacity of the engine oil • The status of links of the fuel system • Looseness or damage of the exhaust pipe and the muffler • The starting of the engine, the noise of the engine • Low speed and acceleration status • Ignition timing • The performance of the muffler
<p>4. The contamination, being clogged of air cleaner element</p>	6 Mon. (4,000km)	<p>(1) Check by eye whether the air cleaner element is contaminated, clogged, damaged or not by disassembling it.</p>

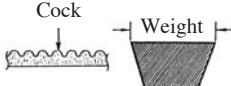
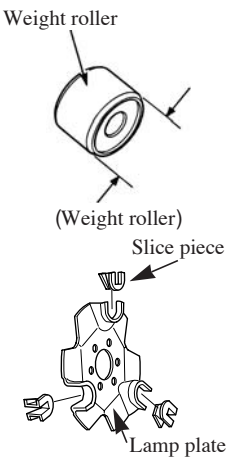
Checking points	Checking timing	Detail checking contents
<p>5. The abrasion, damage of drive belt</p>  <p>(Driver belt)</p>	6 Mon. (4,000km)	<p>(1) Check whether the drive belt is cracked and the cock is chipped off, there is abnormal abrasion. Also, check the width of drive belt.</p>
<p>6. Abrasion, damage of weight roller, slide piece</p>  <p>(Weight roller)</p> <p>(Slice piece)</p>	6 Mon. (4,000km)	<p>(1) Check whether the weight roller in driven pulley is damaged, side worn. Also check the external diameter of weight roller.</p> <p>(2) Check whether the slide piece is damaged, abnormally worn or not.</p>

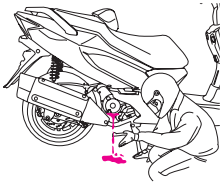
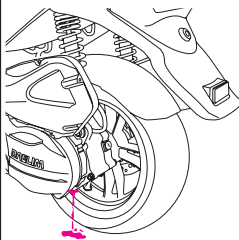
Checking points	Checking timing	Detail checking contents
<p>Lubrication Equipment</p> <p>1. Engine oil / Transmission oil's leakage</p>  	<p>6 Mon. (4,000km)</p>	<p>(1) Check by eye whether there is oil leakage from cylinder, crank case.</p> <p>(2) Check whether there is mission oil leakage from transmission case and check bolts.</p>

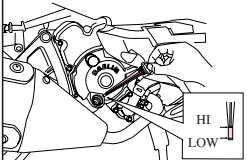
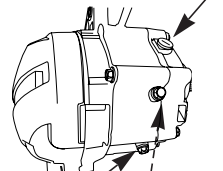
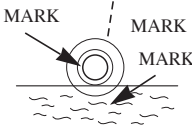
Checking points	Checking timing	Detail checking contents								
<p>2. Checking the quantity of engine oil, transmission oil</p>  <p>(Brake) MARK</p>  <p>MARK</p>  <p>MARK MARK MARK MARK (Brake)</p>	<p>6 Mon. (4,000km)</p> <p>18Mon. (12,000km)</p>	<p>(1) On the condition that the main switch is "ON", check whether the oil caution lamp lights at engine start.(check even at daily inspection)</p> <p>Quantity of engine oil</p> <table border="1" data-bbox="1220 453 1465 533"> <tr> <td>Full</td> <td>1.3 L</td> </tr> <tr> <td>Replacing</td> <td>1.1 L</td> </tr> </table> <p>(2) Check whether the quantity of mission oil reaches to the hole of check bolts by disassembling the oil check bolts.</p> <p>Quantity of transmission oil</p> <table border="1" data-bbox="1220 774 1465 855"> <tr> <td>Full</td> <td>0.15 L</td> </tr> <tr> <td>Replacing</td> <td>0.14 L</td> </tr> </table>	Full	1.3 L	Replacing	1.1 L	Full	0.15 L	Replacing	0.14 L
Full	1.3 L									
Replacing	1.1 L									
Full	0.15 L									
Replacing	0.14 L									

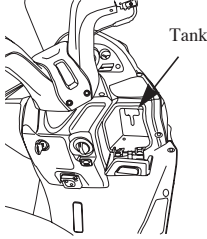
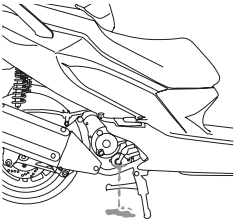

Checking points	Checking timing	Detail checking contents
<p>FUEL SYSTEM (FUEL LINE)</p> <p>1. fuel leakage</p> 	6 Mon. (4,000km)	<p>(1) Check by eye the connection points in which fuel leaks from fuel tank, injector, fuel hose, etc.</p> <p>(2) Check by eye whether fuel hose is damaged, heated.</p>
2. Status of links	12Mon. (8,000km)	(1) Check whether the links in fuel system operates smoothly or not, by testing the throttle grip operation.

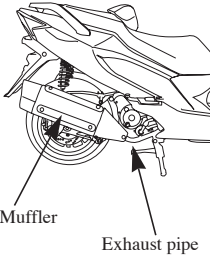
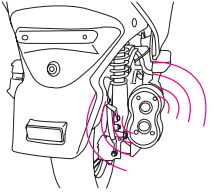
Checking points	Checking timing	Detail checking contents
<p>Cooling system</p> <p>1. Checking the quantity of cooling water.</p> 	6 Mon. (4,000km)	<p>(1) Check whether the quantity of cooling water is within the designated range(between the upper and lower limit)</p> <p>(2) Check whether the cooling fan operates regularly or not.</p>
2. Cooling water leakage	6 Mon. (4,000km)	<p>(1) Check whether the cooling water leaks from radiator, reserve tank, cooling hose, even from the engine.</p> <p>(2) Check by eye whether the cooling hose is cracked, deteriorated.</p> 

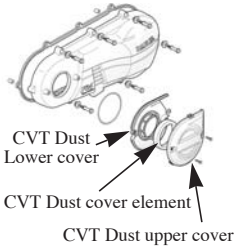
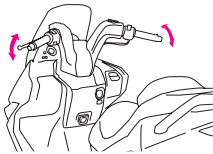
Checking points	Checking timing	Detail checking contents
<p>EXHAUST PIPE and MUFFLER</p> <p>1. Looseness, damage of the connected points</p> 	12Mon. (8,000km)	<p>(1) Check by the spanner whether there is looseness of the connected points between the exhaust pipe and muffler.</p> <p>(2) Check by eye the damage, the leaking out of emission gas, touching with other parts.</p>
<p>2. Function of muffler</p> 	12Mon. (8,000km)	<p>(1) Check by ear whether there is something wrong in the emission sound by changing the RPM value of the engine.</p>

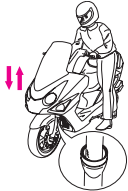
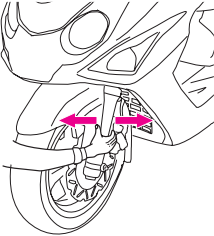
Checking points	Checking timing	Detail checking contents
<p>CVT DUST COVER ELEMENT</p> <p>1. Contaminated, clogged</p> 	6 Mon. (4,000km)	<p>(1) Check by eye whether there is contamination or clog, etc by disassembling the element.</p>
<p>STEERING</p> <p>1. Controlling</p> 	6 Mon. (4,000km)	<p>(1) Erect the main stand and lift up the front wheel then move the steering to the left and right. Check whether the moving to the left and right is smooth or not.</p> <p>(2) Check by eye whether there is twist in the front wheel.</p> <p>(3) At driving, check whether there is unusual heaviness or abnormal vibration and hindrance in operating the steering handle.</p>

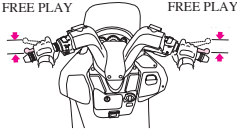
Checking points	Checking timing	Detail checking contents
<p>FRONT FORK</p> <p>1. Damage</p> 	<p>12Mon. (8,000km)</p>	<p>(1) Check by eye whether there is damage in front fork.</p> <p>(2) Check whether there is oil leakage, twist of front fork, abnormal noise by operating the front fork.</p>
<p>2. Status of steering stem's bearing</p> 	<p>12Mon. (8,000km)</p>	<p>(1) Erect the main stand, lift up the wheel and move the lower side of front fork by hand to check whether bearings clattered or not. or, on the condition of operating front brake, moves steering handle to the left and right to check whether the bearings clattered. If necessary, disassemble steering stem and check whether there is abrasion, crack, twisted, etc.</p>

Checking points	Checking timing	Detail checking contents
<p>BRAKE LEVER</p> <p>1. Free play</p> 	<p>6 Mon. (4,000km)</p>	<p>(1) Pull enough the brake lever by hand and check whether the free play is within the designated range or not. Also, when pulling the brake lever, check the softness and whether air inflows by mixing. (Free play of brake lever : 10~20mm)</p>
<p>2. Status of brake performance</p> 	<p>6 Mon. (4,000km)</p>	<p>(1) Drive on the dry road and operates front brake, rear brake separately, then check whether these two brake works well or not. or, by using the brake tester, check whether the braking power is within the designated range or not.</p>

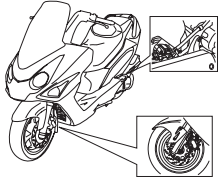
Checking points	Checking timing	Detail checking contents
<p>BRAKE HOSE and PIPE</p> <p>1. Leakage, Damage, Assembling status.</p> 	<p>6 Mon. (4,000km)</p>	<p>(1) Operate the brake strongly, check whether the brake fluid leaks out or not from the brake system.</p> <p>(2) Check whether there is deteriorated, damaged or not in brake hose, pipe and connected points.</p> <p>(3) Check whether connected points or clamps are loose or not. Also, check whether, because of vibration, is interference between steering handle moving to the left/right and hose, pipe, other parts.</p>

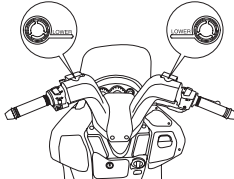
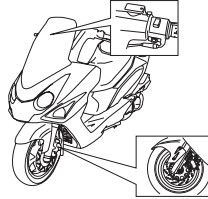
Checking points	Checking timing	Detail checking contents
<p>RESERVE TANK</p> <p>1. The quantity of brake fluid</p> 	<p>6 Mon. (4,000km)</p>	<p>(1) Check by eye whether the fluid quantity of reserve tank is within the designated limit.</p> <p>(2) Check by eye whether there is leakage from the reserve tank.</p>
<p>MASTER CYLINDER and CALIPER</p> <p>1. Function, abrasion, damage</p> 	<p>6 Mon. (4,000km)</p>	<p>(1) Check about movement of cylinder, calipers by the movement of pads from outside.</p> <p>(2) Check whether damage of master cylinder caliper, the leakage by eye.</p>

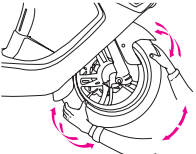
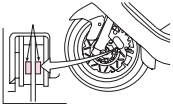
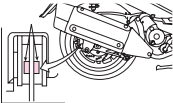
Checking points	Checking timing	Detail checking contents
BRAKE DISK and PADS 1. Gap between disk and pads 	12Mon. (8,000km)	(1) Operate brake a few times and stabilize pads, then erect the main stand, lift up the wheel. Next when rotate the wheel by hand, check whether dragged or not.
2. Abrasion of pads Abrasion limit  Abrasion limit 	6 Mon. (4,000km)	(1) Check the thickness by abrasion limit line(wear indicator).
3. Abrasion, damage of disk	12Mon. (8,000km)	(1) Check by eye whether disk is damaged or worn.

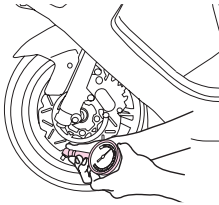
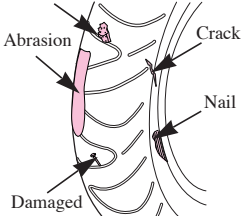
Checking points	Checking timing	Detail checking contents									
WHEEL 1. Tire condition 	6 Mon. (4,000km)	(1) Check whether air pressure is within the designated limit by using tire gauge. <table border="1" data-bbox="1171 316 1513 429"> <thead> <tr> <th></th> <th>1 Person</th> <th>2 Persons</th> </tr> </thead> <tbody> <tr> <td>FR.</td> <td>2.00kg/cm²</td> <td>2.00 kg/cm²</td> </tr> <tr> <td>RR.</td> <td>2.40 kg/cm²</td> <td>2.50 kg/cm²</td> </tr> </tbody> </table>		1 Person	2 Persons	FR.	2.00kg/cm ²	2.00 kg/cm ²	RR.	2.40 kg/cm ²	2.50 kg/cm ²
	1 Person		2 Persons								
FR.	2.00kg/cm ²	2.00 kg/cm ²									
RR.	2.40 kg/cm ²	2.50 kg/cm ²									
		(2) Check by eye whether the tire is cracked or damaged, the nail or stone, other alien materials get stuck to the tire, or side worn of the tire. (3) Check wear indicator(slip line) attached the ground area of tire, or check whether the home length in total ground area of tire is over 0.8mm.									

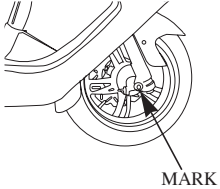
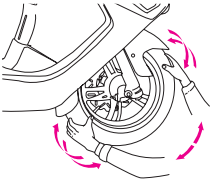
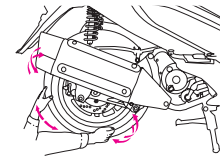
Checking points	Checking timing	Detail checking contents
2. Wheel bolt, nut 	6 Mon. (4,000km)	(1) Check whether assembly of nut assembled between axle shaft and axle holder gets loose or not by spanner.
3. Status of front wheel bearing 	12Mon. (8,000km)	(1) At erecting the main stand, by getting the front wheel fork not moved and moving the tire by grasping its both sides, check whether the front wheel bearing are rattled or not. (2) When, by lifting the wheel, grasp and turn it, check whether the wheel rotates smoothly and whether there is not abnormal noise.
4. Status of rear wheel bearing 	12Mon. (8,000km)	(1) At erecting the main stand and grasp the both sides of tire by hand, check whether the rear wheel bearing get rattled or not. (2) When, by lifting the wheel, grasp and turn it, check whether the wheel rotates smoothly and whether there is not abnormal noise.

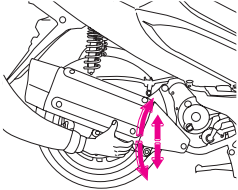
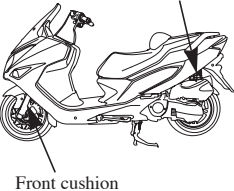
Checking points	Checking timing	Detail checking contents
SWING ARM 1. Status of assembled points and damage of swing arm 	12Mon. (8,000km)	(1) Check by hands whether the assembled points like swing arm, engine hanger link get rattled or not. (2) Check by eye whether there is any damage on swing arm. also, check whether the fixing bolts of swing arm, engine hanger link get rattled or not, by spanner
CUSHION 1. Damage, oil leaking Rear cushion  Front cushion	12Mon. (8,000km)	(1) Check by eye whether there is oil leakage in front cushion and rear cushion and damage.

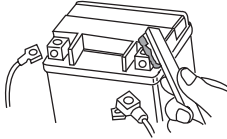
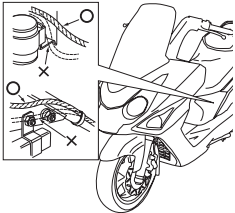
Checking points	Checking timing	Detail checking contents
<p>BATTERY</p> <p>1. Connecting status of terminals</p> 	6 Mon. (4,000km)	(1) Check by eye whether there is looseness and corrosion in terminals.
<p>ELECTRIC WIRES</p> <p>1. Looseness, damage of connecting positions</p> 	12Mon. (8,000km)	<p>(1) Check by hands whether there is looseness in connecting positions of electric wires.</p> <p>(2) Check by eye whether there is any interference in wires at the time when the steering handle moves.</p> <p>(3) Check by eye whether there is looseness in clamp and damage in electric wires.</p>
2. Checking of fuse	12Mon. (8,000km)	(1) Turn off the main switch and check whether the fuse is cut or not.

Checking points	Checking timing	Detail checking contents
<p>SWITCHES</p> <p>1. Operating of lights, signals</p> 	6 Mon. (4,000km)	(1) Check by eye whether there is any problem in light on/off by operating head light, tail light, stop lamp, wipers(signals).
2. Operating horn	12Mon. (8,000km)	(1) By operating the horn, check about the sound volume and quality.
3. Operating handle lock	12Mon. (8,000km)	(1) Check whether by operating the main switch lever and moving the handle, the handle is locked or not.

Checking points	Checking timing	Detail checking contents
<p>3. Meter</p> 	<p>12Mon. (8,000km)</p>	<ol style="list-style-type: none"> (1) Check whether the gauge of speedometer operates without matter or not. (2) Check whether the odometer works without matter or not. (3) Check whether other meters works without matter or not, according to the specified measurement methods.

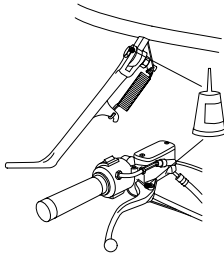
Checking points	Checking timing	Detail checking contents
<p>FRAME</p> <p>1. Frame</p>	<p>12Mon. (8,000km)</p>	<p>(1) Check whether the bolts, nuts of frame are loose or not with the spanner. Also, check by eye whether there is damage on the frame body or not.</p>
<p>OTHERS</p> <p>1. Refueling of other positions of frame body</p> 	<p>12Mon. (8,000km)</p>	<p>(1) Check by eye whether the refueling is done enough to each other position of frame body or not.</p>

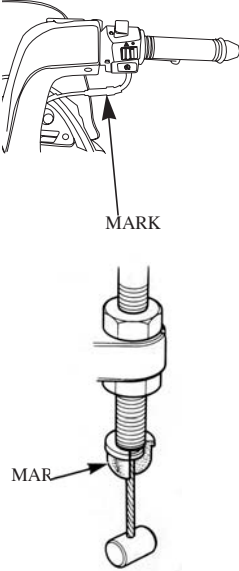
Checking points	Checking timing	Detail checking contents
<p data-bbox="114 253 331 273">2. Rubber bush of cables</p> 	<p data-bbox="367 280 430 330">6 Mon. (4,000km)</p>	<p data-bbox="443 280 769 353">(1) Check by eye whether the rubber bushes are correctly assembled or not.</p>

INSPECTION RECORDS

REPLACEMENT CHECKING SHEET FOR OILS, CONSUMABLE PARTS

CHECK	V	REPLACE	R	ASSEMBLY	T	REPAIR	△
CLEAN	C	ADJUST	A	REFUEL	L		

REFUEL	YEAR, MONTH, DATE
	DISTANCE	km	km	km	km	km	km
BRAKES	BRAKE FLUID						
	BRAKE PAD						
ENGINE	SPARK PLUG						
	ENGINE OIL						
	TRANSMISSION OIL						
	COOLING WATER						
	WEIGHT ROLLER						
	SLICE PIECE						
	DRIVER BELT						
OTHERS	BATTERY						
	TIRE						
	FUEL FILTER						

**REPLACEMENT CHECKING SHEET
FOR OILS, CONSUMABLE PARTS**

CHECK	√	REPLACE	R	ASSEMBLY	T	REPAIR	△
CLEAN	C	ADJUST	A	REFUEL	L		

REFUEL	YEAR, MONTH, DATE
	DISTANCE	km	km	km	km	km	km
BRAKES	BRAKE FLUID						
	BRAKE PAD						
ENGINE	SPARK PLUG						
	ENGINE OIL						
	TRANSMISSION OIL						
	COOLING WATER						
	WEIGHT ROLLER						
	SLICE PIECE						
	DRIVER BELT						
	BATTERY						
OTHERS	TIRE						
	FUEL FILTER						

REPLACEMENT CHECKING SHEET FOR OILS, CONSUMABLE PARTS

CHECK	✓	REPLACE	R	ASSEMBLY	T	REPAIR	△
CLEAN	C	ADJUST	A	REFUEL	L		

REFUEL	YEAR, MONTH, DATE
	DISTANCE	km	km	km	km	km	km
BRAKES	BRAKE FLUID						
	BRAKE PAD						
ENGINE	SPARK PLUG						
	ENGINE OIL						
	TRANSMISSION OIL						
	COOLING WATER						
	WEIGHT ROLLER						
	SLICE PIECE						
	DRIVER BELT						
OTHERS	BATTERY						
	TIRE						
	FUEL FILTER						

**REPLACEMENT CHECKING SHEET
FOR OILS, CONSUMABLE PARTS**

CHECK	√	REPLACE	R	ASSEMBLY	T	REPAIR	△
CLEAN	C	ADJUST	A	REFUEL	L		

REFUEL	YEAR, MONTH, DATE
	DISTANCE	km	km	km	km	km	km
BRAKES	BRAKE FLUID						
	BRAKE PAD						
ENGINE	SPARK PLUG						
	ENGINE OIL						
	TRANSMISSION OIL						
	COOLING WATER						
	WEIGHT ROLLER						
	SLICE PIECE						
	DRIVER BELT						
OTHERS	BATTERY						
	TIRE						
	FUEL FILTER						

- Performing daily inspection
- Putting on the protective gears (Helmet, glove, goggles, etc.)
- Bringing the driver's licence
- Determinating the path to the desired destination

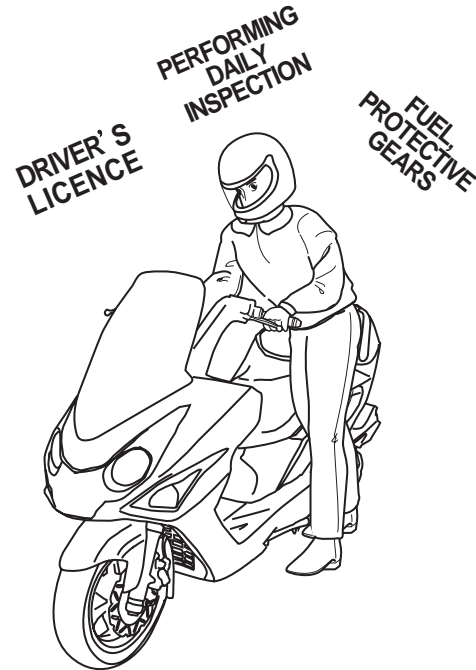

DRIVING POSITION

The appropriate driving position is most important thing to driving safely.

- ① Eyes : Look at the front direction widely.
- ② Shoulders : Relieve the tension.
- ③ Arms : Relieve the tension and bend arms to inside and let them act as the spring.
- ④ Hands : Grip the handle the position away from the inside end of the handle with distance of one finger to facilitate the operation of the switch and lever.
- ⑤ Wrist : Keep the state to act freely without applying excessive force to the shoulder and arms.
- ⑥ Knees : Press the fuel tank slightly.
Feet : Place the feet to face the front parallel and make the step bar be placed in the center of feet.

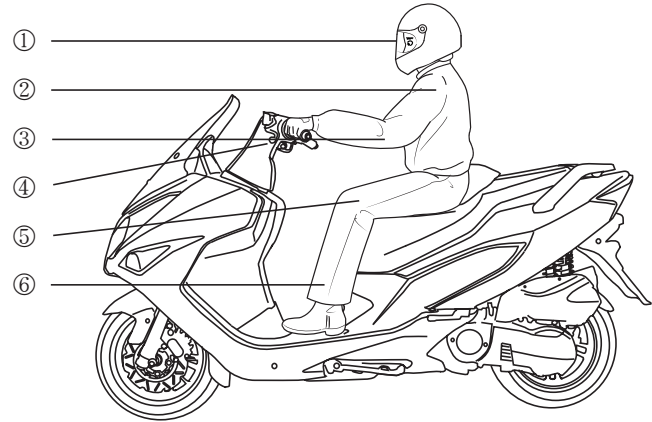

TAKING POSE OF FELLOW PASSENGER

- ① Hands: Hold the rear grip.
- ② Feet and knees: Put the feet on pillion step, and adhere the knees closely to body.

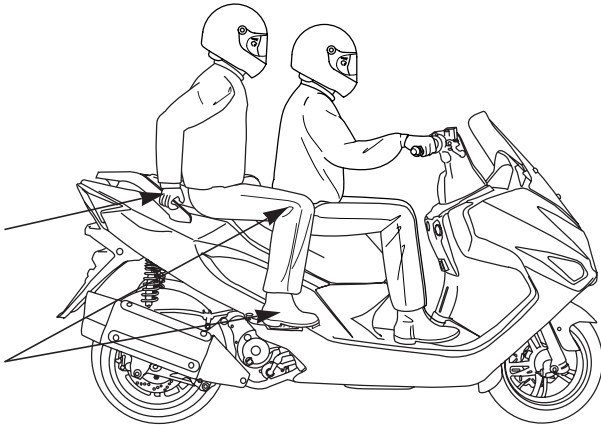

⚠ WARNING

- the fellow passenger doesn't hold the rear grip or put the step on the pillion step, it may lead death or serious injury due to falling from the vehicle as sudden start, stop or turning.
- Do not operate the throttle while setting the main stand. If the fellow passenger sit on and the rear wheel touch the ground, it may lead death or serious injury due to sudden start.

PRECAUTION WHEN DRIVING

- Secure the safe distance.
- Drive protectively.
- Do not obstruct the traffic.
- Do not drive on the pedestrian way or walkway.
- Drive on the left driveway when passing away.
- Make sure that you can apply the brake anytime.
- Always apply the brake when stopping temporarily.
- Do not drive excessively long distance and take enough break.
- If any abnormality is found, stop driving and contact service center to inspect the vehicle.
- Restart the vehicle after 2~3 min when it is turned over.
- Always turn on the headlight at night.

STARTING

Prior to starting always look around to avoid accident.

- ① Get on the vehicle after pulling back the stand.
- ② Start driving slowly after turning on the winker and releasing the brake while ensuring the safety around the vehicle.

CAUTION

- Return the side stand to its original position. Keep driving without doing this may cause turnover accident.
- Drive the vehicle only on the driveway. Driving on the walkway can cause accident. Also, if the wheel is transformed when advancing directly to the walkway, the vehicle can be overturned resulting in injury of the driver due to the driving instability.
- Overspeed driving on the unpaved road can cause the vehicle to be overturned resulting in injury of the driver due to the driving instability.
- Do not drive in the gravel road. If any gravel enters the wheel or engine case, the vehicle can be overturned resulting in injury of the driver.
- If possible, do not drive close to the sea or on the road where calcium chloride is treated.
- The muffler, external parts and welded parts can be corroded rapidly, and also in case of damage of the frame, the vehicle can be overturned resulting in injury of the driver.

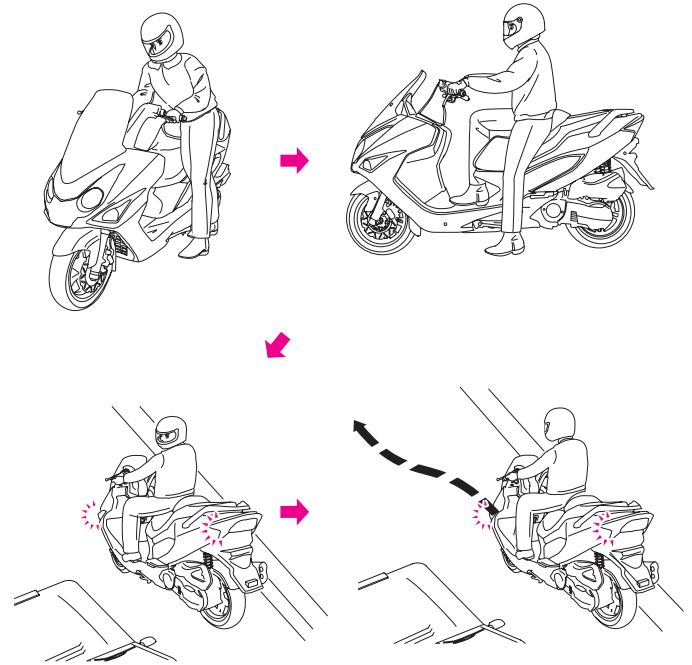

TURNING METHOD

PRINCIPLE OF TURN

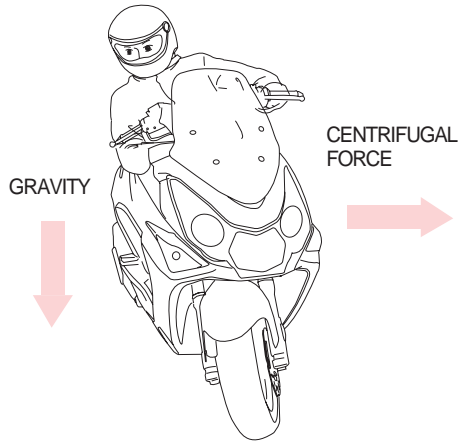

The basic principle of turn is balancing using the centrifugal force which makes vehicle go outside and the gravity which makes vehicle fall inside.

EFFECT OF SPEED

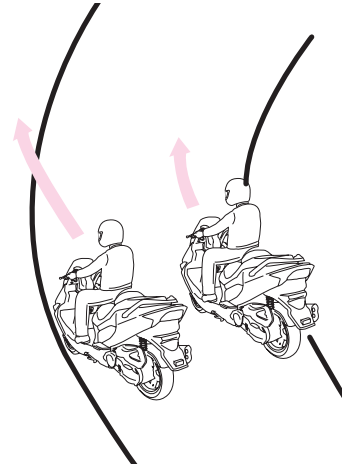

The centrifugal force increases in inverse portion to the radius of a curve and in portion to the square speed. Decelerate prior to entering the curved way to reduce the centrifugal force.

3 POSITIONS OF TURNING

The basic principle of turn is balancing using combined force of the centrifugal force and the gravity.

All 3 positions require straightening the head and keeping the eyes horizontally.

< LEAN-WITH >

This is a turning position with motorcycle and driver in a line.

This position is the most natural and exact, so driver must learn it thoroughly.

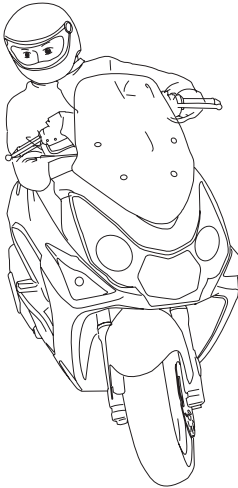

< LEAN-IN >

This is a turning position with driver leaned inside more than motorcycle. This position is adequate to drive on the rained or slippery road because it has best road holding.

However, special attention is required because front visual field is poor when driver leans inside more than motorcycle.

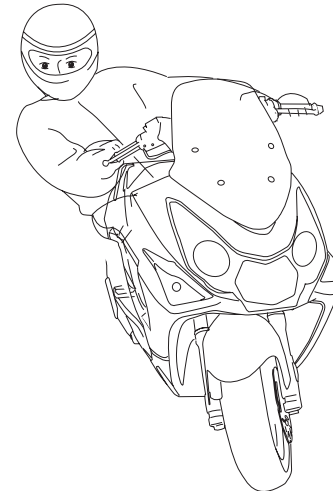

TURNING METHOD

< LEAN-OUT >

This is a turning position with motorcycle leaned inside more than driver, which is opposite to the lean-in position. With this position, quick turn is well performed and driver can obtain wide front visual field adequate to drive on the rained or slippery road because it has best road holding. However, special attention is required because there is danger of slipping on the bad holding road.

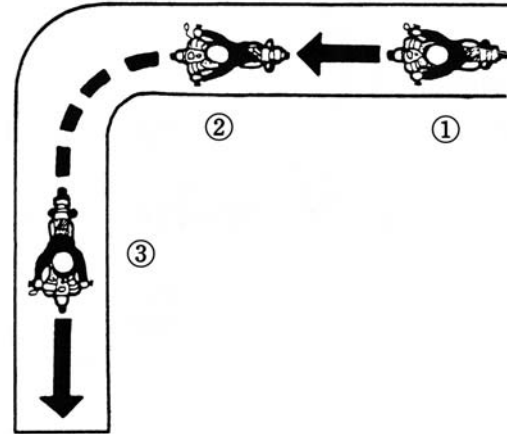
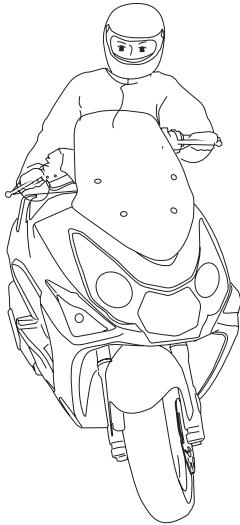

- ① Turn the throttle grip to its original position and decelerate using both front and rear brakes.
- ② Lean the vehicle toward inside of turn circle while driving slowly at constant speed.
- ③ Accelerate gradually.

PRECAUTION WHEN TURNING

Do not drive inside of large truck's turn circle.

< DEAD ANGLE ZONE >

Dead angle zone is the sight range which cannot be identified by driver and increases in proportion to the width of the vehicle.

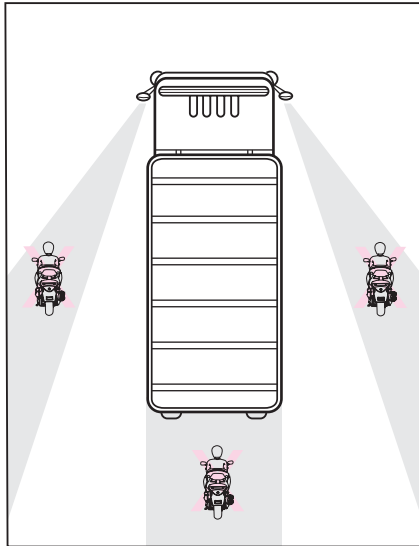

< DISTANCE BETWEEN THE FRONT AND REAR WHEEL TURN >

It is distance between path of the front and rear wheel and increases in proportion to the length of the vehicle.

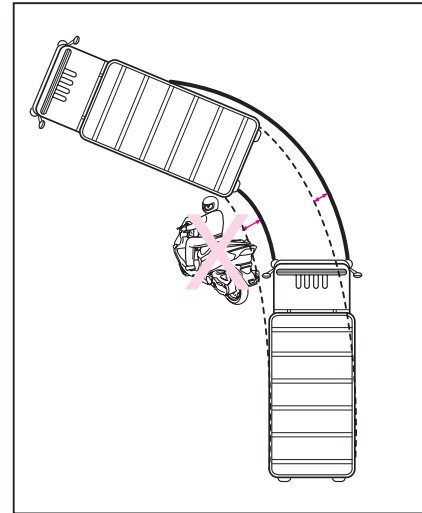

BRAKING METHOD

BASIC PRINCIPLE OF BRAKING (FRICTION FORCE)

- Vehicle is braked using friction between road surface and tires.
- Braking distance increases 1.5 times on wet road and 3 times on icy road because friction force of road surface is decreased.

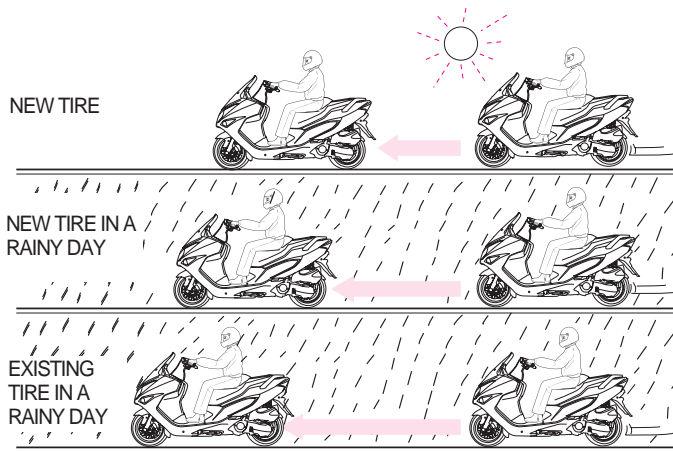

RESTRAINT OF BRAKE EFFECT (INERTIA)

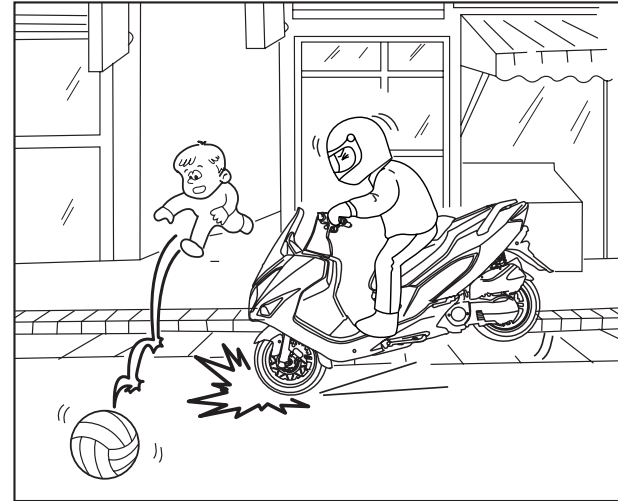

Due to the inertia, vehicle does not stop immediately after applying the brake.

BRAKING METHOD

- Turn the throttle grip to its original position and decelerate using the engine brake.
- Erect the vehicle straight.
- Brake using both front and rear brakes.

COMPARISON OF BRAKING DISTANCE

- Vehicle speed : 50 km/h

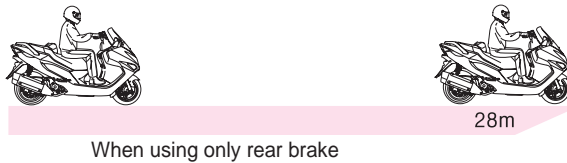
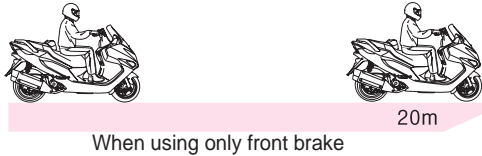
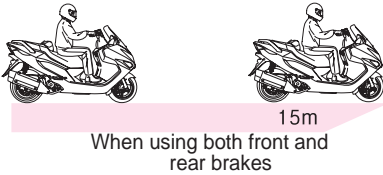

IMPACT AT COLLISION

Learn the proper braking method to prevent accident.

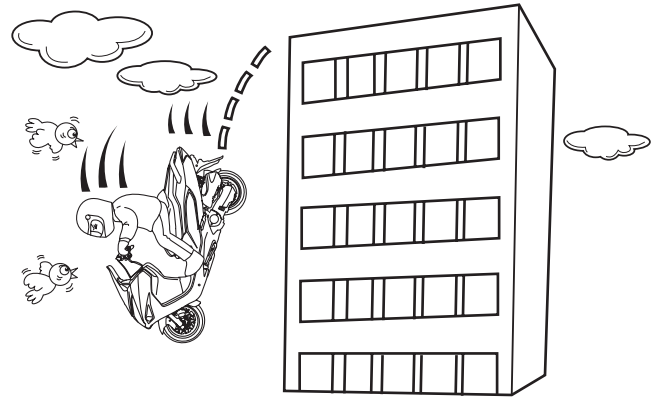

Impact increases in proportion to the speed and weight. The impact when collision to concrete wall at 50 km/h is same as one when falling from the height of 10m.

WIRING DIAGRAM

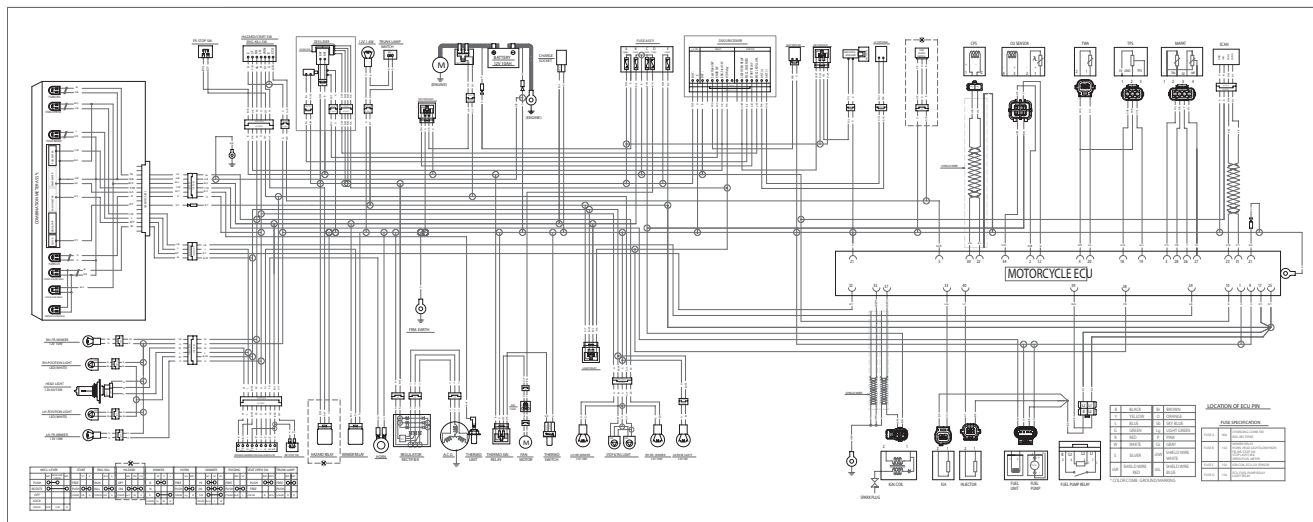

MEMO :

A series of horizontal dotted lines for writing.

MEMO :



A series of horizontal dotted lines providing a template for writing a memo.

MEMO :



A series of horizontal dotted lines providing a template for writing a memo.

MEMO :

A series of horizontal dotted lines for writing.



OWNER'S MANUAL

2010. 8 PRINTED
2010. 8 PUBLICATION

NO COPY

 **DAELIM MOTOR**



■ HEAD OFFICE(FACTORY)

#58, SUNG SAN-DONG, CHANG WON, KYUNGNAM, KOREA

TEL: (82-55) 239-7000 / FAX: (82-2) 467-9997